

CS:4980

Foundations of Embedded Systems

Introduction

Copyright 20014-16, Rajeev Alur and Cesare Tinelli.

Created by Cesare Tinelli at the University of Iowa from notes originally developed by Rajeev Alur at the University of Pennsylvania. These notes are copyrighted materials and may not be used in other course settings outside of the University of Iowa in their current form or modified form without the express written permission of one of the copyright holders. During this course, students are prohibited from selling notes to or being paid for taking notes by any person or commercial firm without the express written permission of one of the copyright holders.

Embedded Software Systems Everywhere!

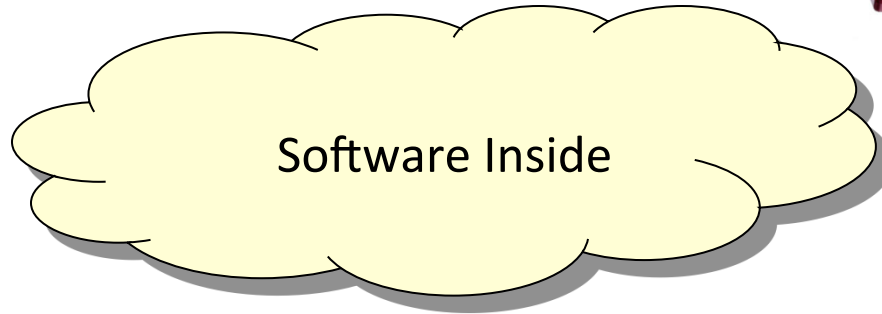

From Desktops to Cyber-Physical Systems

- ❑ Traditional computers: Stand-alone device running software applications (e.g., data processing)

- ❑ Traditional controllers: Devices interacting with physical world via sensors and actuators (e.g., thermostat)

- ❑ Embedded (aka Cyber-physical) Systems
 - Special-purpose system with integrated microcontroller/software
 - Cameras, watches, washing machines, ...

Cyber-Physical Systems



Driverless Cars

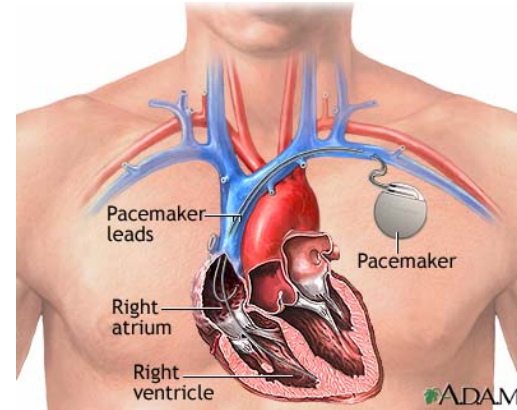

Medical devices



Coordinating robots

Cyber-Physical Systems

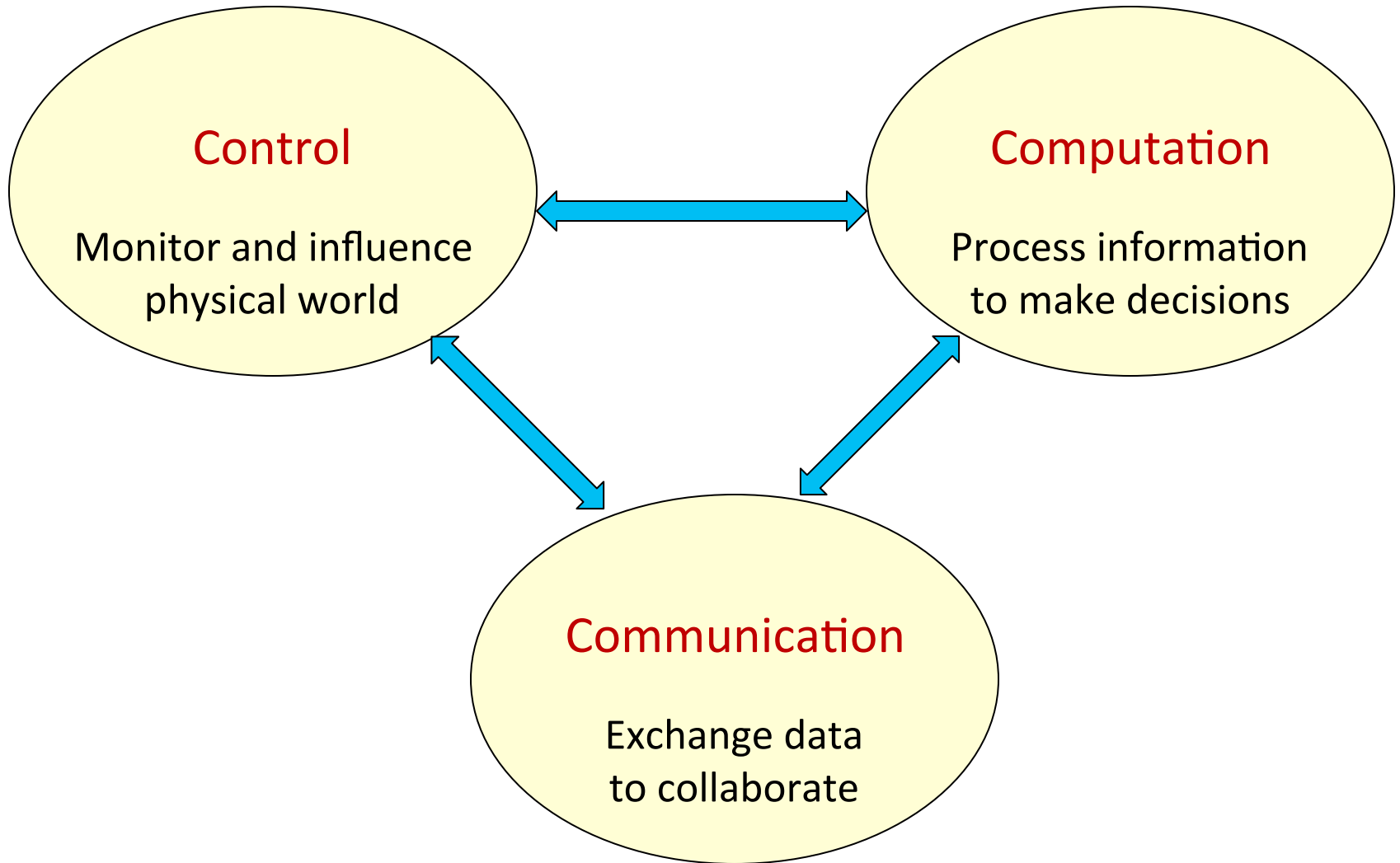

Design of Cyber-Physical Systems

Systems that integrate control, computation, and communication
can do cool things

and useful things

Lots of promise and potential: medicine, transportation, energy, ...

So what's the main challenge?

Ariane 5 Explosion



“It took the European Space Agency 10 years and \$7 billion to produce Ariane 5. All it took to explode that rocket less than a minute into its maiden voyage last June, scattering fiery rubble across the mangrove swamps of French Guiana, was a small computer program trying to stuff a 64-bit number into a 16-bit space”

A bug and a crash, J. Gleick, New York Times, Dec 1996

Prius Brake Problems Blamed on Software Glitches

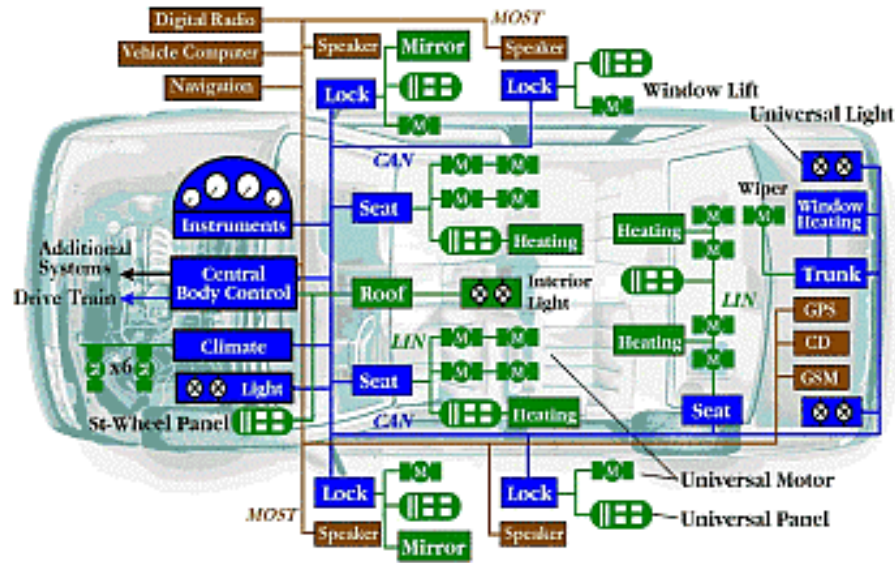

“Toyota officials described the problem as a "disconnect" in the vehicle's complex anti-lock brake system (ABS) that causes less than a one-second lag. With the delay, a vehicle going 60 mph will have traveled nearly another 90 feet before the brakes begin to take hold”

CNN Feb 4, 2010

Software: The Achilles' Heel

Software everywhere means bugs everywhere

2002 study by NIST:

Software bugs cost US economy \$60 billion annually (0.6% of GDP)

Lack of trust in software as technology barrier

Would you use an autonomous software-controlled round-the-clock monitoring and drug-delivery device?

Software: The Achilles' Heel

Software everywhere means bugs everywhere

2002 study by NIST:

Software bugs cost US economy

Lack of trust in software as technology

Would you use an autonomous drug-delivery device?



oring and

A grand challenge for computer science:

Technology for designing **reliable** cyber-physical systems

Designing a Cruise Controller



What's the goal of a cruise controller?

Automatically adjust the speed of the car so that it matches the speed desired by the driver

Block Diagrams of High-Level Design

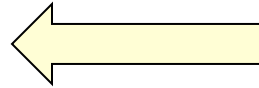

How does this component interact with the rest of the world ?

Interfaces for Components: Inputs and Outputs

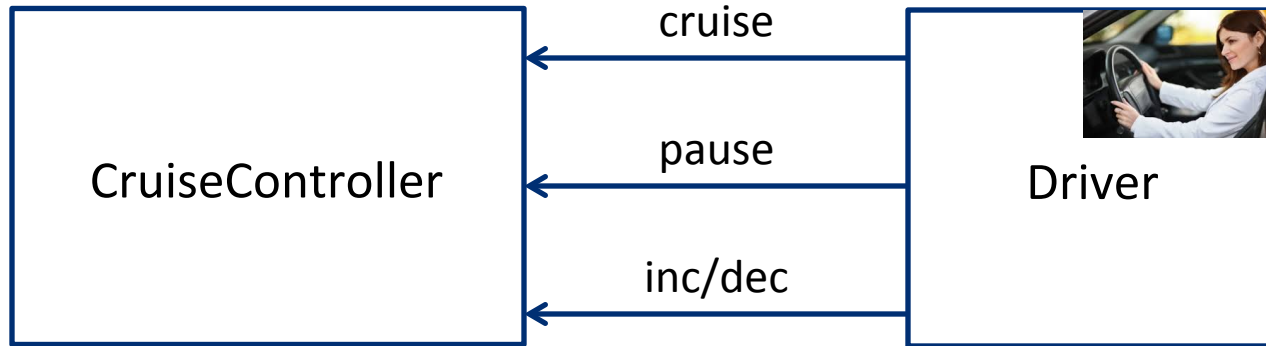

Driver interacts with the system using 4 buttons:

Cruise button to turn the cruise on or off

Pause button to suspend/restart its operation

Inc and **Dec** buttons to increment or decrement desired speed

Interfaces for Components: Inputs and Outputs

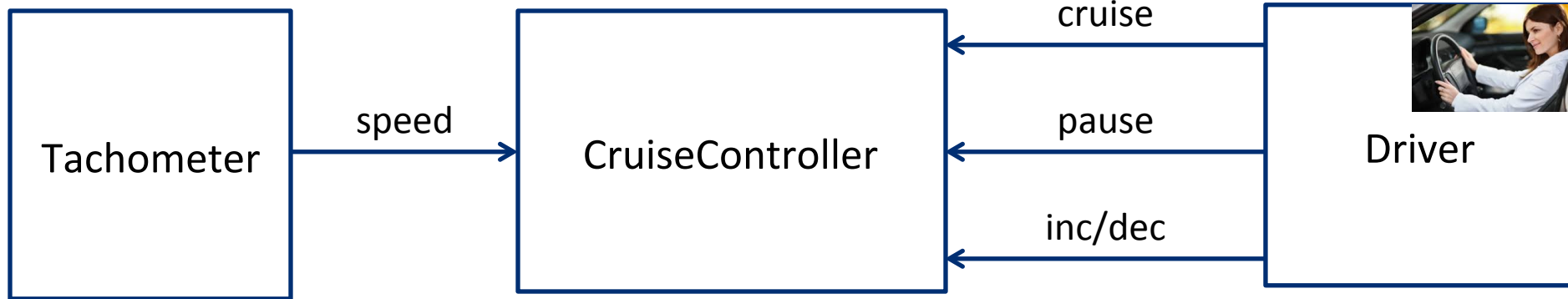

What other information does the cruise controller need ?

And who supplies it?

Interfaces for Components: Inputs and Outputs

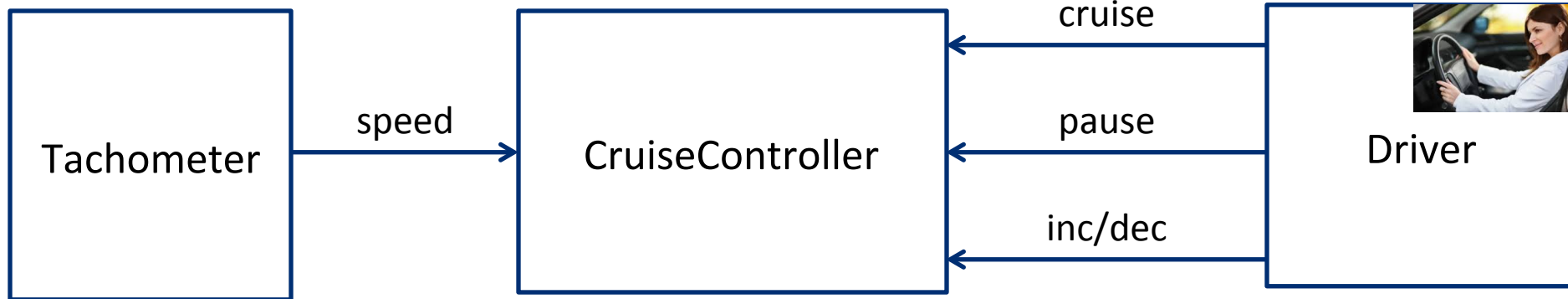

What should be the outputs of the cruise controller?

And who needs these outputs?

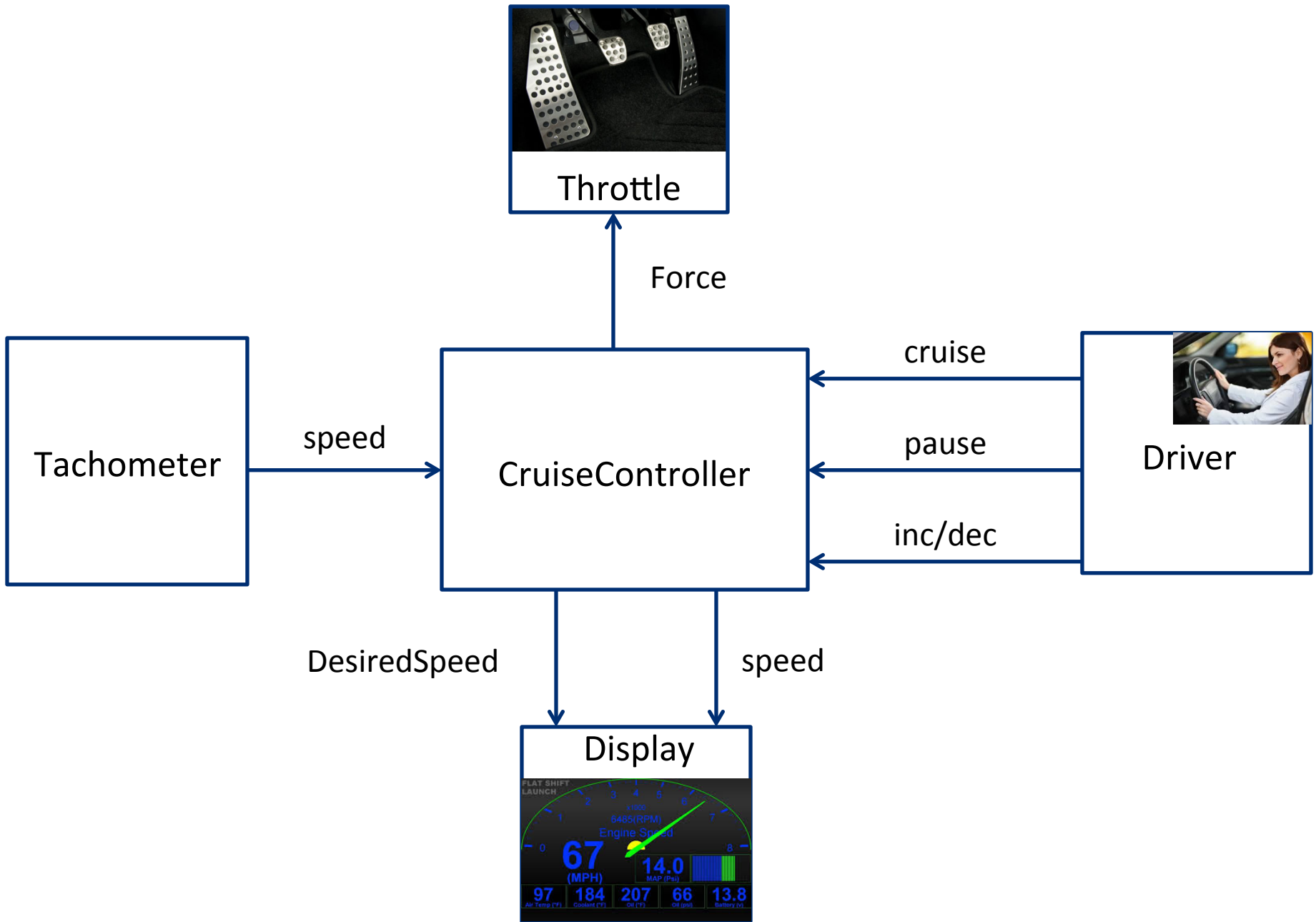

Compositional Design

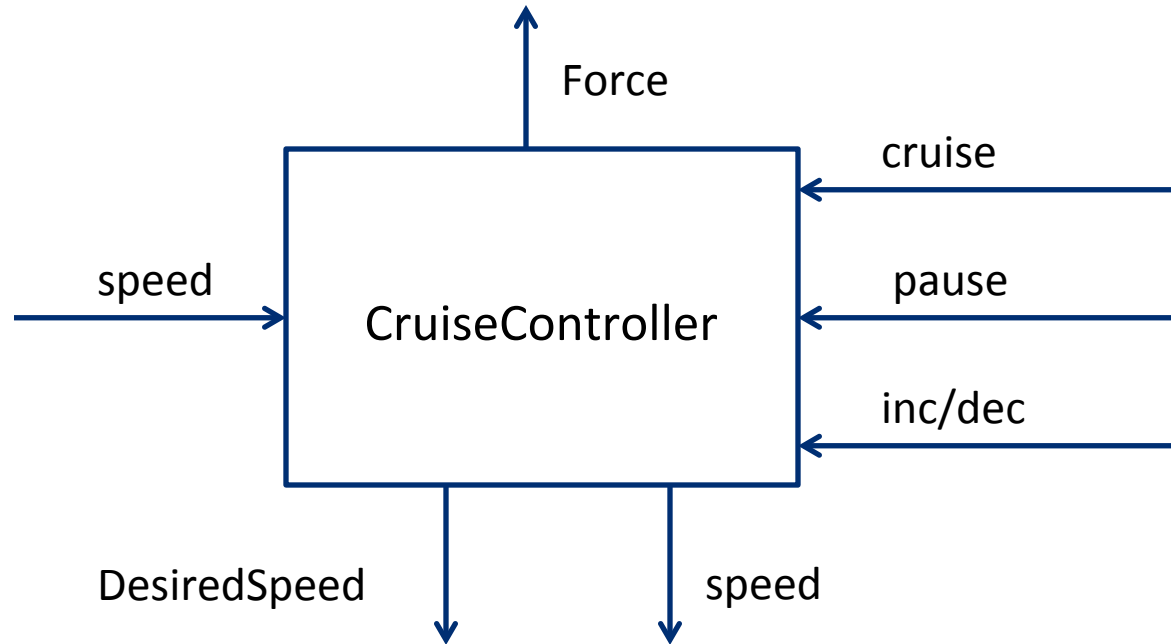

How to break up the computation of the cruise controller into subtasks?

Decomposing the Cruise Controller

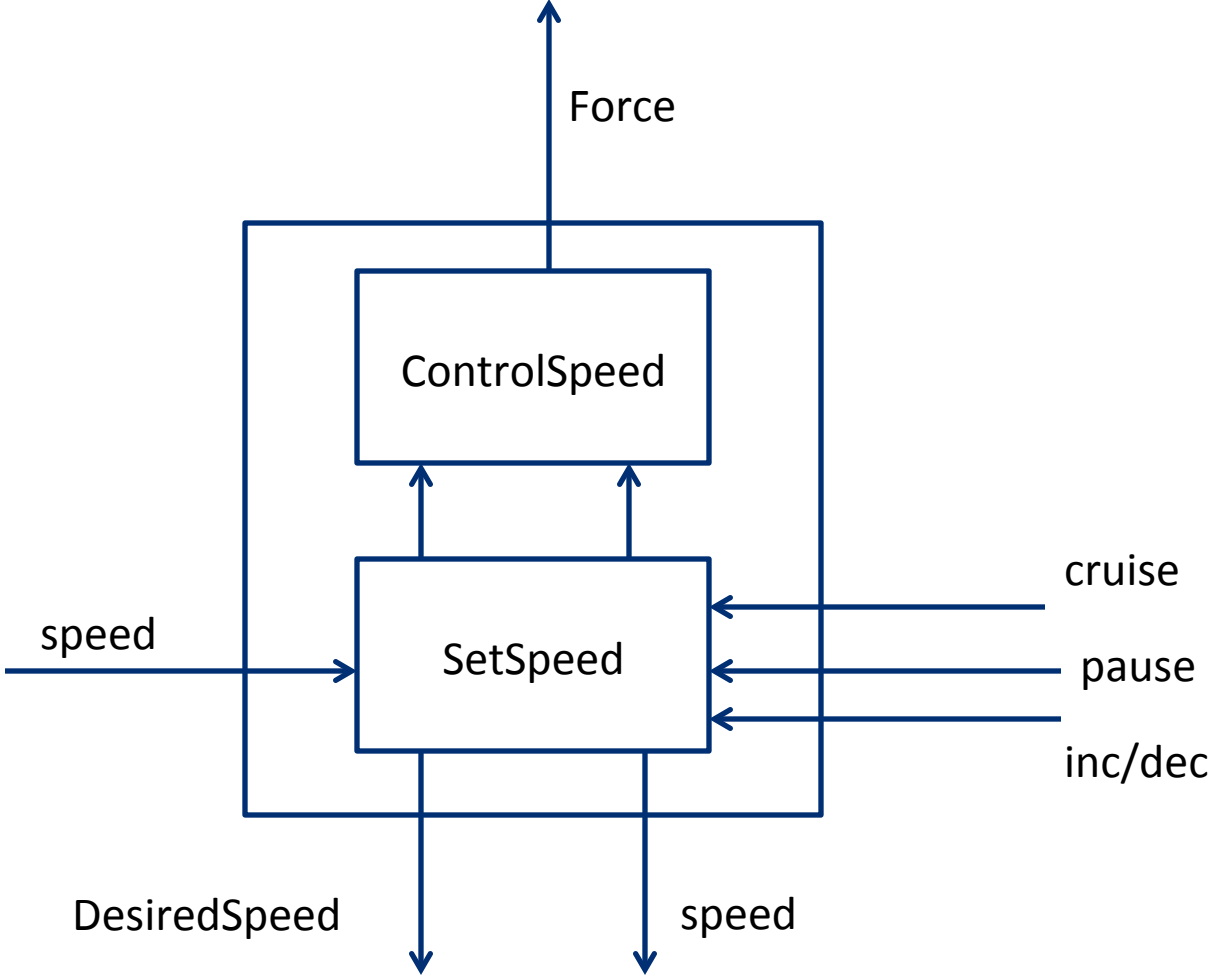

Designing SetSpeed Component

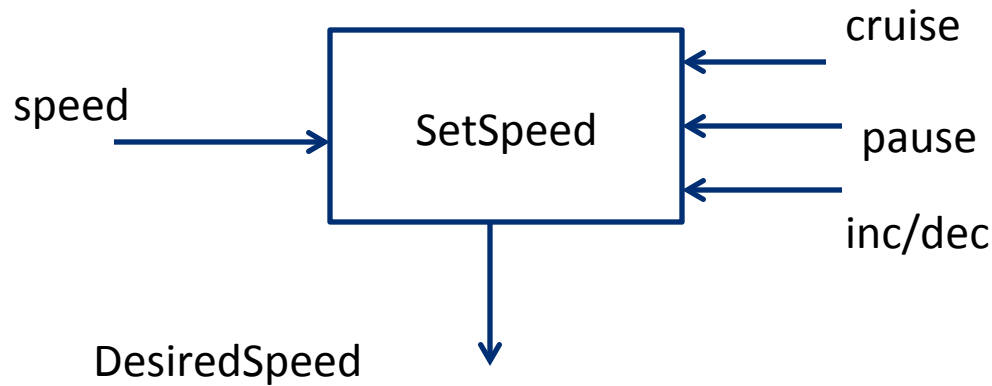

Goal: Compute the desired cruising speed in response to the commands from the driver

Designing SetSpeed: State Machines

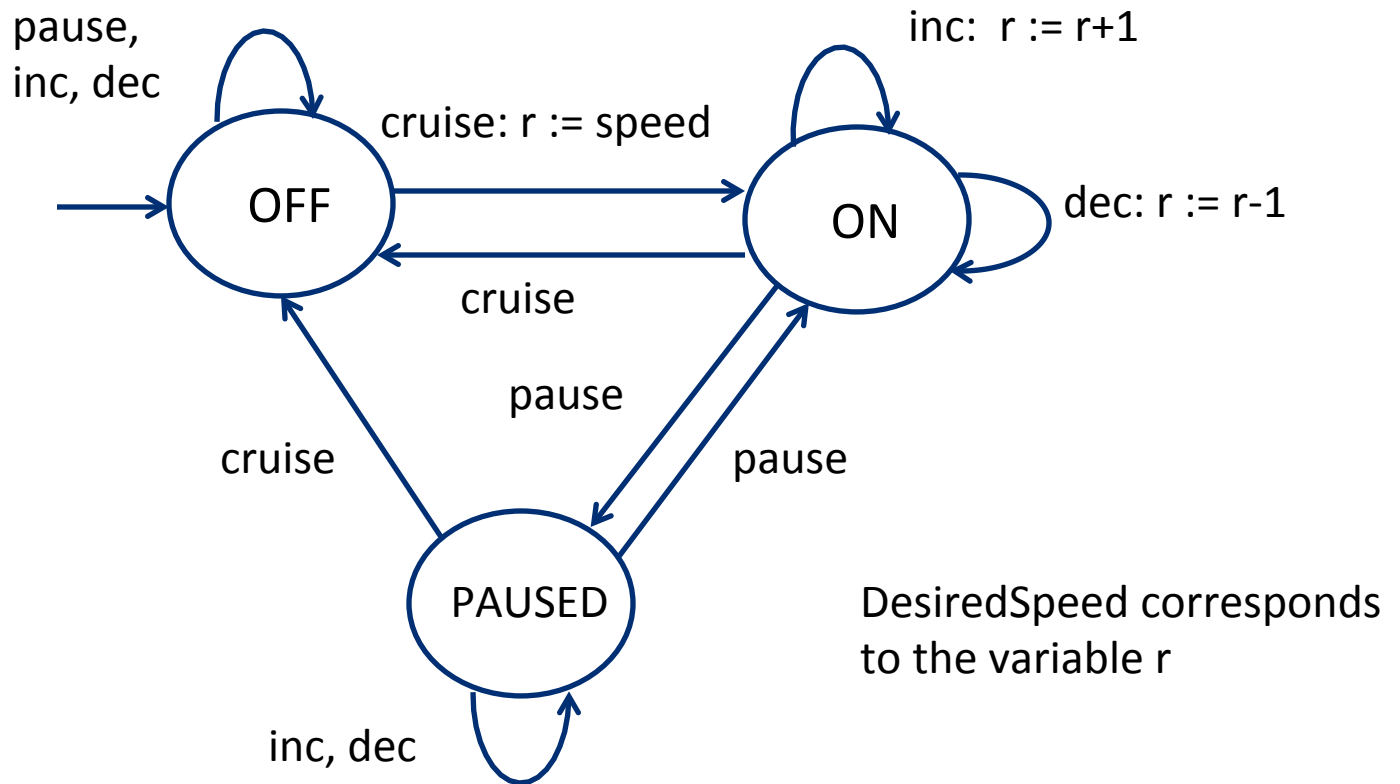

Designing ControlSpeed Component

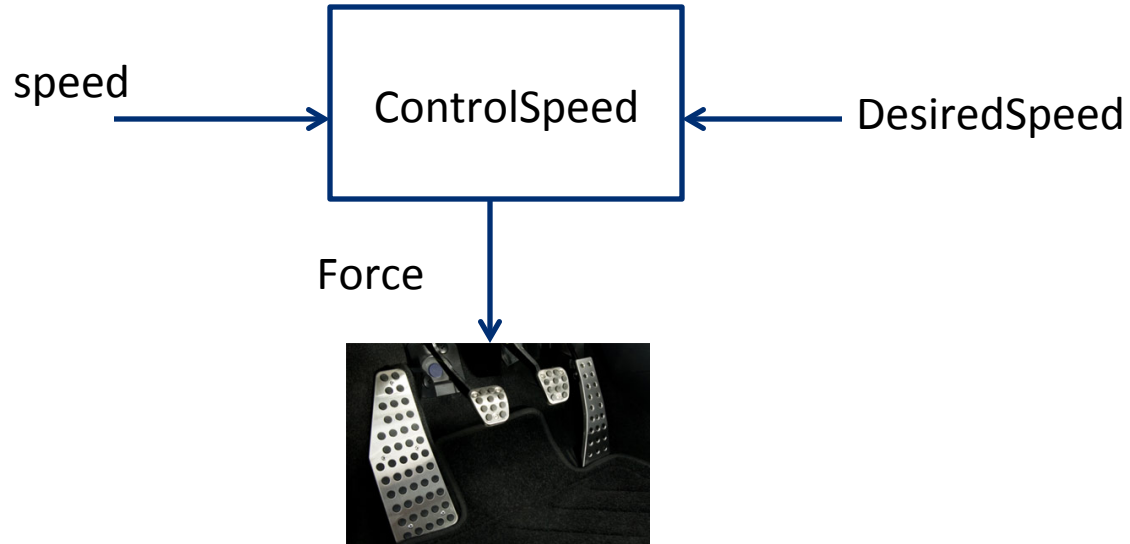

Goal: Determine the force to be applied to throttle so that speed becomes equal to DesiredSpeed

Capturing Requirements

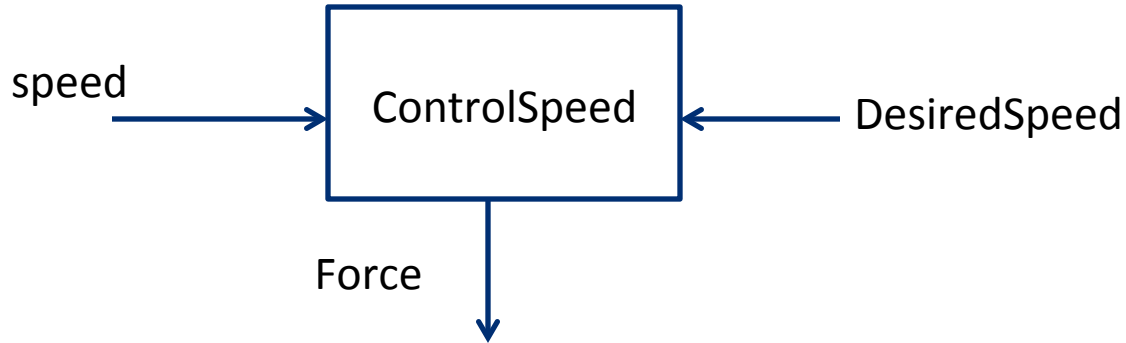

Requirements: Mathematically precise description of what a system is supposed to do.

Writing requirements is key to ensuring reliability of systems

Requirement 1: Actual speed eventually **converges** to desired speed

Requirement 2: Speed of the car stays **stable**

A bit of Physics: Modeling a car

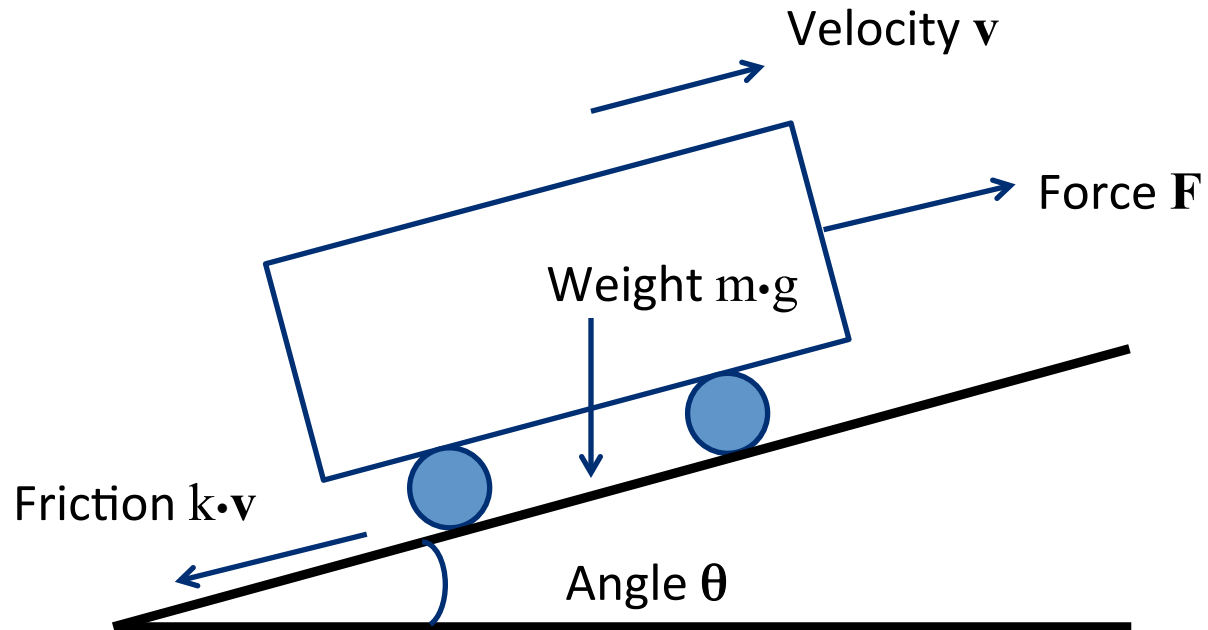

Newton's law of motion gives

$$F - k \cdot v - m \cdot g \cdot \sin \theta = m \cdot a$$

$$a = \dot{v}$$

ControlSpeed Component

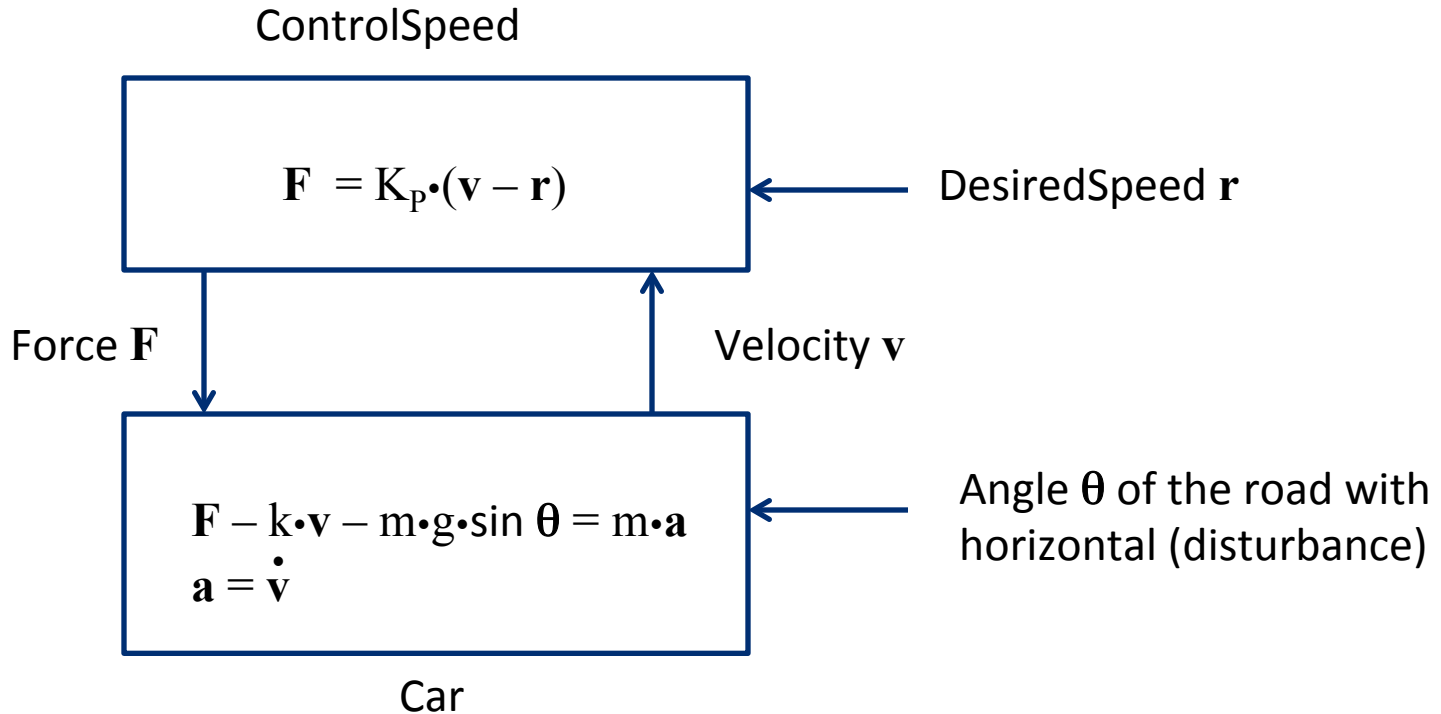

Control Theory: Mathematical techniques to compute force (\mathbf{F}) as a function of velocity (\mathbf{v}) and desired speed (\mathbf{r})

Does our controller work ?

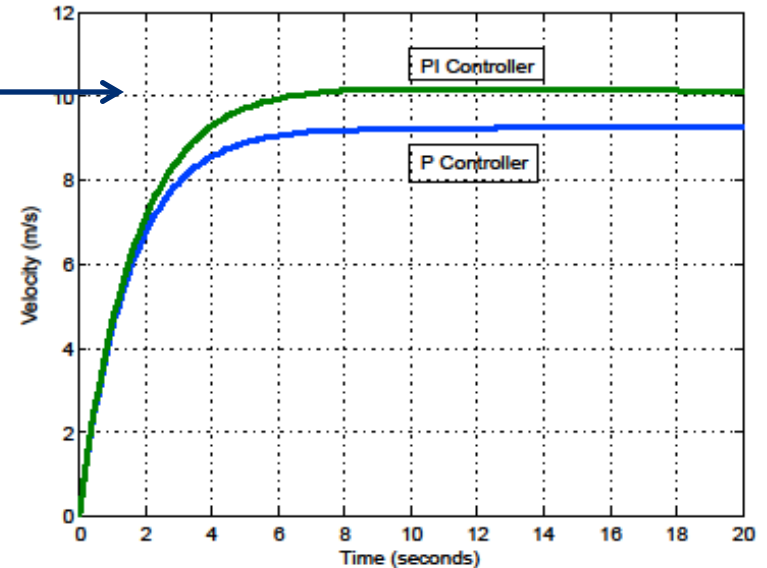
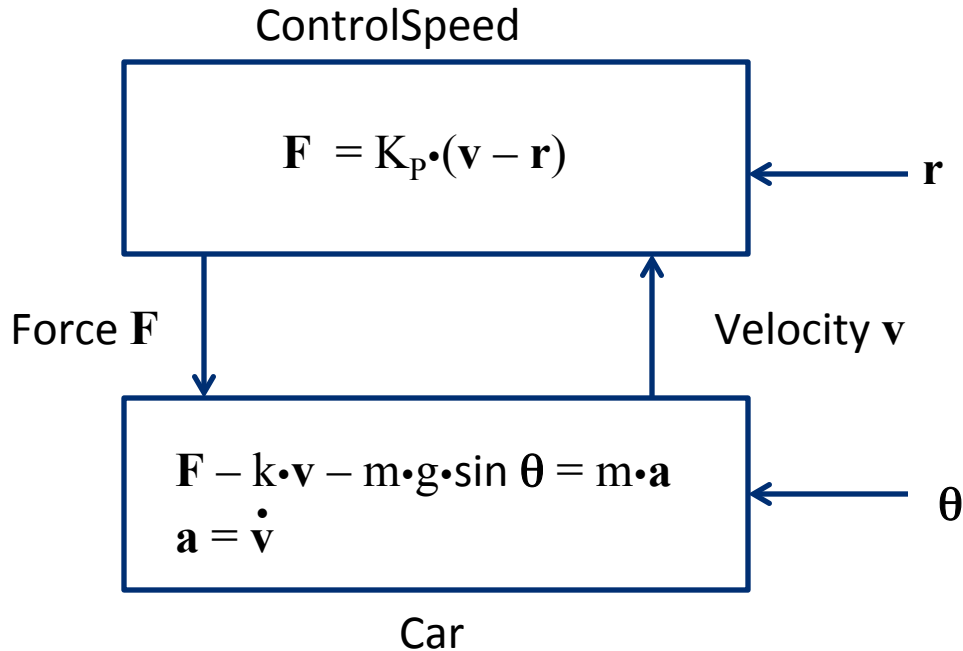

Verification Tools: Allow you to check if system model indeed works as expected, that is, satisfies requirements

Model-based design != Coding

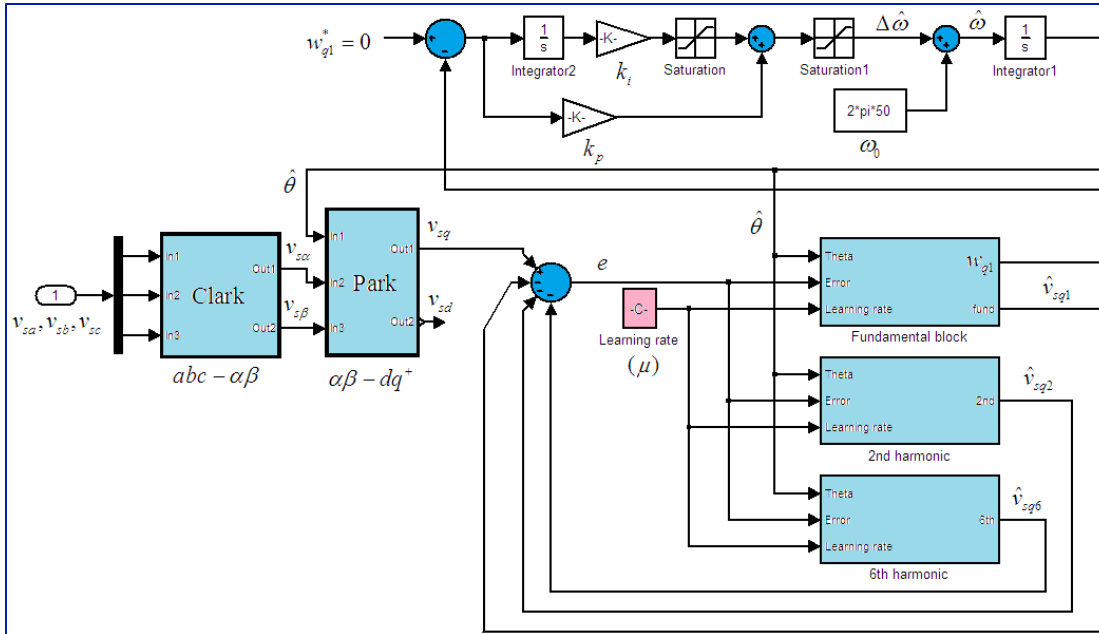

```

1
2 #make sure that we are allowed to recurse many times
3 import sys
4 sys.setrecursionlimit(20000)
5
6
7 def probOfStreak(numCoins, minHeads, headProb, saved=None):
8     #Computes the probability (i.e. S[n,k]) of getting a run of minHeads
9     #(i.e. K) or more heads in a row out of numCoins
10    #(i.e. N) independent coin tosses where the probability of getting a
11    #heads each time is headProb (i.e. p) and the
12    #probability of a tails is 1-headProb (i.e. q).
13    #We will be using the recursion:
14    #S[N,K] = p^K + sum_{j=1,K} p^{j-1} (1-p) S[N-j,K]
15    #As well as the base cases S[0,k] = 0 and S[N,K] = 0 for K>N
16
17
18    #if it's our first call, allocate a hash table to store saved values
19    if saved == None: saved = {}
20
21    #get a unique identifier for the value that they want to compute
22    ID = (numCoins, minHeads, headProb)
23
24    #if it has been computed before, just return the precomputed value.
25    #there is no point in wasting time computing the same thing again.
26    if ID in saved: return saved[ID]
27
28    else: #if it's never been computed before
29        #handle the base case where we have no coins or where we have
30        #more heads we are looking for than we have coins
31        if minHeads > numCoins or numCoins <= 0:
32            result = 0
33        else:
34            #use our recursive relationship to compute S[n,k] by
35            #breaking it into a sum of terms involving S[n-j,k] for 1<=j<=k
36            result = headProb**minHeads #S[n,k] = p^k + ...
37            #S[n,k] = ... + sum_{j=1,k} p^{j-1} (1-p) S[n-j,k]
38            for firstTail in xrange(1, minHeads+1):
39                pr = probOfStreak(numCoins-firstTail, minHeads, headProb, saved)
40                result += (headProb**(firstTail-1))*(1-headProb)*pr
41            #save the resulting value so that we can use it later, if need be
42            saved[ID] = result
43
44    #return the computed value
45    return result

```

Design using high-level block diagrams and state machines gets automatically compiled into low-level code!

Models not only of system being designed, but also of its environment

Verification != Simulation/Testing

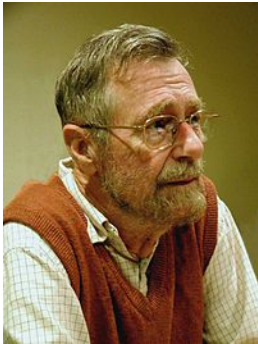

Program testing can be used to show the presence of bugs, but never their absence!

Edsger W. Dijkstra

Formal Verification



- ❑ **Goal:** Establish that model satisfies requirements under all possible scenarios
- ❑ **First challenge:** Need formal definitions of **model** and **requirement** to make the problem mathematically precise
- ❑ **Second challenge:** Need verification techniques and tools

Course Topics

- ❑ Goal: Introduction to principles of design, specification, analysis and implementation of CPS
- ❑ Disciplines
 - Model-based design
 - Concurrency theory
 - Distributed algorithms
 - Formal specification
 - Verification techniques and tools
 - Control theory
 - Real-time systems
 - Hybrid systems
- ❑ Emphasis on mathematical concepts

Theme 1: Formal Models

- ❑ Mathematical abstractions to describe system designs
- ❑ Modeling formalisms
 - Synchronous models (Chapter 2 of textbook)
 - Asynchronous models (Chapter 4)
 - Continuous-time dynamical systems (Chapter 5)
 - Timed models (Chapter 7)
 - Hybrid systems (Chapter 9)
- ❑ Modeling concepts
 - Syntax vs. semantics
 - Composition
 - Input/output interfaces
 - Nondeterminism, fairness, ...

Theme 2: Specification and Analysis

- ❑ Formal techniques to ensure correctness at design time
- ❑ Requirements
 - Safety (invariants, monitors)
 - Liveness (temporal logic, automata over infinite sequences)
 - Stability
 - Schedulability
- ❑ Analysis techniques
 - Deductive: Inductive invariants and ranking functions
 - Enumerative and symbolic search for state-space exploration
 - Model checking
 - Linear-algebra-based analysis of dynamical systems
 - Verification of timed and hybrid systems

Theme 3: Model-based Design

- ❑ Design and analysis of illustrative computing problems
- ❑ Design methodology
 - Structured modeling (bottom-up, top-down)
 - Requirements-based design and design-space exploration
- ❑ Case studies
 - Distributed coordination: mutual exclusion, consensus, leader election
 - Communication: Reliable transmission, synchronization
 - Control design: PID, cruise controller
 - CPS: Pacemaker, obstacle avoidance for robots, multi-hop control network