

## A BRAILLE PRINTER

Andrew W. Appel and Douglas W. Jones  
Medical Computing Laboratory  
School of Basic Medical Sciences  
University of Illinois  
Urbana, IL 61801

### 1. Introduction

This braille printer design resulted from the observation that existing braille printers were either slow and expensive, or very expensive. These printers use relatively old designs, and contain many moving parts. Furthermore, they require a significant amount of software support from the host computer. On the basis of these observations, and a quick check of the unit prices of key components (micro-computer, stepping motors, and solenoids), it was determined that a fast braille printer with a built in micro-computer could be built for about \$1000 worth of parts (1979 cost). The inclusion of the microcomputer would greatly simplify the mechanical design.

Two printers representative of the current state of the art are SAGEM's TEM/REM 8 BR and TRIFORMATION's LED-120. The SAGEM printers run at 15 characters per second, while the LED-120 runs at 120 characters per second. Both printers are implemented with "random" electronic logic, although the LED-120 uses some LSI; both use mechanical control systems. Both printers accept the ASCII character set and literally map 64 of the characters to the 64 braille signs (including space). The mapping provided is correct for the letters in Grade 1 English Braille, but departs from this for the remainder of the character set. Thus, typical computer output is difficult for even trained users to interpret, and special translation programs are required if standard Grade 1 or Grade 2 English Braille are to be produced.

The construction of this printer was financed by the School of Basic Medical Sciences and the School of Clinical Medicine of the University of Illinois at Urbana Champaign. The Physics Department supported the project with its machine shop facilities, and the microcomputer was purchased with Federal funds. Initial software for the microcomputer was written by students from Computer Science 350. Thanks for this support are due to: Frank Mabry, Bruce Sherwood, Peter Maggs, and A. B. Baskin.

## 2 Functional Overview

The mechanical operation of the printer is quite simple. There are two stepping motors, one responsible for paper advance, and one for carriage motion. The carriage itself carries three solenoids, one for each of the three rows of bosses which make up braille text. The paper is embossed by stylus points ground on the ends of the solenoid plungers. Each stylus mates with a matching row of dies in the back bar (above the paper) which shape the bosses in the paper. While one solenoid is embossing the upper right dot of one character, another will be positioned under the center right dot of the character five print positions over, and the third will be positioned under the bottom right dot ten positions over.

The interface electronics performs the function of using the logic levels appearing on the outputs of the microcomputer to control the power delivered to the motors and solenoids. Additionally, the interface electronics includes a loudspeaker to be used for audible indication of various printer conditions. Stepping motors have multiple windings; motor rotation is accomplished by energizing the windings in the appropriate sequence. Thus, one bit is needed to control each of the windings. There are 4 windings on the large carriage motion motor, and three on the paper advance motor. Allocating one bit to the speaker and one to each of the three solenoids, a total of eleven bits are needed from the microcomputer.

The microcomputer itself is responsible for timing the transitions on each of the output bits to produce the desired mechanical motion, polling the input switches, and managing the asynchronous communications line. The input switches include an internal "carriage at left margin" switch and three internal mode switches, as well as the external page feed, line feed, and braille level select switches. Since each switch may be on or off, this is seven input bits. The microcomputer has the responsibility for translating the incoming ASCII characters to braille, and for converting the braille to motor and solenoid control sequences. Should the microcomputer discover anything wrong, it will signal this on the speaker. It may also transmit status reports on the asynchronous line.

The prototype achieves at present a speed of 13 characters per second. With patient optimization of the software delays to reduce resonance problems, a speed of 20 or 30 characters per second is likely.

## 2.1 The ASCII Printing Characters

ASCII (the American Standard Code for Information Interchange) is a 7 bit code for the entire alphabet in upper and lower case, the digits, 32 punctuation and accent marks, space, and 33 control characters. The 7 bits are numbered 0 to 6, with bit 0 being the least significant (rightmost) and bit 6 being the most significant (leftmost). In traditional communications terminology, the binary one and zero are called mark and space. On a serial communications line, the ASCII codes are sent least significant bit first. Asynchronous transmission involves a leading mark at the start of each character, and at least one trailing space at the end. These are called start and stop bits. On the RS-232 interface, marks are represented by negative voltages, spaces by positive voltages.

The ASCII character set is traditionally presented as a matrix, where the 3 most significant bits of the 7 bit representation label the columns and the 4 least significant bits label the rows. The printing characters occupy most of columns 2 through 7 (codes 20 to 7E). Note that space (code 20) is considered to be a printing character; the remaining codes are the control characters (codes 00 to 1F and code 7F, shaded in the diagram).

		COLUMNS									
		0	1	2	3	4	5	6	7		
	0	≠	≠	≠	≠	0	@	P	`	p	
	1	≠	≠	≠	≠	!	!	A	Q	a	q
	2	≠	≠	≠	≠	"	2	B	R	b	r
	3	≠	≠	≠	≠	#	3	C	S	c	s
	4	≠	≠	≠	≠	\$	4	D	T	d	t
	5	≠	≠	≠	≠	%	5	E	U	e	u
R	6	≠	≠	≠	≠	&	6	F	V	f	v
O	7	≠	≠	≠	≠	'	7	G	W	g	w
W	8	≠	≠	≠	≠	(	8	H	X	h	x
S	9	≠	≠	≠	≠	)	9	I	Y	i	y
	A	≠	≠	≠	≠	*	:	J	Z	j	z
	B	≠	≠	≠	≠	+	;	K	[	k	{
	C	≠	≠	≠	≠	,	<	L	\	l	
	D	≠	≠	≠	≠	-	=	M	]	m	}
	E	≠	≠	≠	≠	.	>	N	^	n	~
	F	≠	≠	≠	≠	/	?	O	_	o	≠

Note that on some printers and terminals, the ^ and \_ characters are presented as ^ and \_ and . Sometimes, the 7F code is used as a printing character. These changes are not part of the ASCII standard. It is standard to use the ' as either an accent mark (acute), as an apostrophe or as a single quote.

## 2.2 The ASCII Control Characters

The control characters are divided into broad groups which can be distinguished by the first two letters of their CCITT names as follows:

- TC - transmission control.
- FE - format effector, used to position data for display.
- DC - device control, for auxiliary function control.
- IS - information separator, used for machine processing.

The control characters which have meanings when recieved by

the printer are marked by an asterisk while those which it transmits are marked with a plus in the following table. Note that the CCITT name follows in parentheses when it differs from the ASCII name. All unmarked characters in the following table are ignored by the printer; most of these are simply not applicable, but NUL and DEL must be ignored.

code	name	code	name
00	NUL	10	DLE (TC7)
01	SOH (TC1)	11	*DC1
02	STX (TC2)	12	DC2
03	ETX (TC3)	13	DC3
04	EOT (TC4)	14	DC4
05	*ENQ (TC5)	15	+NAK (TC8)
06	+ACK (TC6)	16	SYN (TC9)
07	*BEL	17	ETB (TC10)
08	*BS (FE0)	18	CAN
09	*HT (FE1)	19	EM
0A	*LF (FE2)	1A	SUB
0B	*VT (FE3)	1B	ESC
0C	*FF (FE4)	1C	FS (IS4)
0D	*CR (FE5)	1D	GS (IS3)
0E	SO	1E	RS (IS2)
0F	SI	1F	US (IS1)
7F	DEL		

ENQ - on receipt, causes an ACK to be transmitted when the printer is able to accept more data, unless there is an error condition, in which case it will send a NAK.

BEL - on receipt, sounds a brief (1/4 second) tone (2khz).

BS - on receipt, signals that the next character will overprint the previous character. See note on braille overprinting.

HT - on receipt, advances the print position to the next tab stop.

LF - on receipt, terminates current line, advances to next line. Note special interaction with overprinting.

VT - same as LF, but advances paper by only half as much.

FF - on receipt, terminates current line and advances to top of next page (assumes 11 inches to the page).

CR - on receipt, terminates current line; any printing characters arriving before the next line terminator will overprint the previous line from the beginning. See note on braille overprinting.

ESC - when followed by one of the following codes, switch printing modes. Otherwise, both the ESC character and the following character are ignored.

'4' - Use "transparent" mode, in which the low-order 6 bits of any printing character

directly correspond to the 6 dots of the braille cell.

- '5' - Use the Provisional Braille Code for Computer Notation.
- '6' - Use English Braille, grade 1 or 2, depending upon the setting of the internal mode switch.

These remain in effect until another escape sequence is sent, or until the mode switch on the top of the printer is switched.



the and for with of  
 (ie: = the length of the arrow was 15 inches .)

## 2.4 ASCII to Braille Translation

This braille printer has four modes in which it can interpret the ASCII printing characters. The primary two modes are Grade 1 and Grade 2 Braille; in these modes, the internal microprocessor does its best to produce readable output which corresponds to these two standards. The third mode of operation is transparent mode, in which a remote computer can directly control the printer operation for applications such as music or math braille, Grade 3 Braille, or more complete adherence to the rules of Grade 2 Braille. The fourth is the Provisional Braille Code for Computer Notation, which may be particularly appropriate for transcribing computer programs.

Selection between computer notation and english braille is accomplished both by remotely sent escape sequences, and by a switch switch on the top of the printer. This is because the nature of the material being printed governs the grade which is appropriate. For example, if a computer program is being printed, exact spelling and punctuation are important, so computer notation should be used; on the other hand, when printing text, grade 2 will save a considerable amount of paper, and is faster to read.

Transparent mode is entered whenever ESC 4 is received and remains in effect until the next escape sequence, or or until the mode select switch on top of the printer is switched. In transparent mode, the control characters are interpreted normally, but the ASCII meanings of the printing characters are ignored. Instead, the least significant 6 bits of the ASCII character are taken to indicate the 6 positions in the cell to be printed. The bit - dot relation is:

ASCII bit number:	6	5	4	3	2	1	0
Braille dot number:	x	1	2	3	4	5	5

A note on overprinting: In many computer applications, two or more characters are printed over each other. For example, "b" overprinted with "/" ("b/") is commonly used as a printing character for blank. Some programming languages, such as APL, make very extensive use of overprinting. Braille presents significant difficulties for overprinting because the superposition of any two braille characters simply produces another character. This printer solves this problem by printing overprints with a vertical displacement of 2 dots. As a result, any line containing overprints will be 5 dots high (instead of the normal 3), and the space to the next line will be appropriately increased. Multiple overstrikes will be simply superimposed, and overprinting

of spaces will not cause any displacement. Incidentally, this solution allows the 8 dot cell supported by the TRIFORMATION LED-120 to be reproduced.



English Braille, grade 1, is currently supported on this printer. Following is a list of rule references taken from "English Braille, American Edition", indicating which rules for grade 1 Braille are supported.

## I. Punctuation Signs

All supported as given except:

- Opening double quotation mark: no ASCII equivalent
- Opening single quotation mark: no ASCII equivalent; apostrophe is used.
- Closing single quotation mark: same.
- Ellipsis: Three periods are used, as in ASCII.

1. Use and order of punctuation follows input text.
2. See above
3. Supported exactly
4. Supported exactly
5. Supported; follows input text.
6. Follows input text. (ASCII will use -- for dash)
7. See above
8. Following order will be used:
  - Open parenthesis or bracket
  - Open quotation sign  
(Italics not supported in ASCII)
  - Apostrophe
  - Capital or letter sign
  - Accent sign

## II. Special Braille Composition Signs

9. Supported almost exactly. The only case among the examples given on page 11-12 of the ink-print edition which is printed differently is C/O, in which the second capital sign would be omitted.
10. Italics are not supported in ASCII.
11. Not supported.
12. Supported:
  - a.
    - (1) When any uncapitalized letter, not just those from "a" to "j", follows a number or is separated by a hyphen following a number, the letter sign will be used.
    - (2) Letters standing alone in the input text will be preceded by a letter sign.
    - (3) Combinations of letters standing alone will NOT be preceded by a letter sign; individual letters will.
    - (4) Letter sign will be used.
  - b.
    - (1) Supported.
    - (2) Letter sign will be used for uncapitalized letters.
    - (3) Letter sign will be used for uncapitalized k-z.
    - (4) Letter sign will be used for uncapitalized k-z.
    - (5) Letter sign will be used when apostrophe follows.
    - (6) Letter sign will be used when period follows.

13. Follows input text.

VIII. Numbers

28. Cardinal numbers

- (a) Supported
- (b) Supported
- (c) Supported
- (d) Not supported.
- (e) Mostly supported.
- (f) Period is used instead of 4-6 for decimal point.
- (g) Supported, except for decimal point.
- (h) Follows input text.
- (i) Follows input text.
- (j) Supported, except that hyphen ( - ) is used for minus. Note that in standard ASCII practice, asterisk is used for times, and slash is used for divide. Dot 4 precedes the words for the symbols +, =, <, etc., as per section 31-a.  
Translations:

- + (dot 4) plus
- = (dot 4) eq
- < (dot 4) lt
- > (dot 4) gt

29. Follows input text.

30. Follows input text.

Text may be printed according to the Provisional Braille Code for Computer Notation (1972). Only sections 3 and 10 pertain to the printing of computer programs, and both are supported exactly (note that only those characters in section 3 which are present in the ascii character set can be supported).

## 2.5 Operation of the Braille Printer:

The printer is a compact unit, measuring 12" by 24" by 5". It was designed with the needs of the blind user in mind, so it is extremely simple to operate. Loading the paper is accomplished by feeding it under a bar, positioning the holes (which run down both sides of the paper) over the appropriate pins (which protrude through the top of the printer), and lowering two levers (which automatically snap into place). The whole operation takes only a few seconds even for someone unfamiliar with the machine.

The paper on which braille has just been printed travels across the top of the printer from front to back, so that the lines which have just been printed may be read.

The number of external controls has been minimized; there are, of course, no indicators could not be read by a blind person (there are no indicators at all!). There are four controls, all located on the top of the printer, and easily accessible:

1. On-Off switch
2. English Braille / Computer notation select switch.
3. Form Feed button
4. Line Feed button

There are a few internal control switches which need be set only at installation time or when maintenance is being done on the printer:

1. Wide/Narrow paper selection
2. Baud Rate selection
3. Run/Test mode selection

### Variable Paper Widths:

The printer can accomodate either 9.5-inch-wide paper (that is, 8.5 inch paper with a half-inch track on either side for sprocket holes), or 12-inch wide paper. Switching between the two paper widths requires a screwdriver.

- 3 Construction
  - 3.1 Bottom Assembly
    - 3.1.1 Baseplate
    - 3.1.2 Back Assembly
      - 3.1.2.1 Back Plate
      - 3.1.2.2 Fan Assembly
        - 3.1.2.2.1 Fan  
PAMOTOR Miniature Fan, Model 8500 C, 115v, 60Hz, 43cfm.
        - 3.1.2.2.2 Finger Guard  
PAMOTOR Fingerguard, Model 5508.
        - 3.1.2.2.3 Fuse Holder  
LITTELFUSE 3AG Panel Fuseholder, No. 341001;  
with 3AG 3A fuse, L.F. No. 312003.
        - 3.1.2.2.4 Line Cord  
BELDEN 3-Conductor Line Cord, 16 awg, 9 ft, No. 17419s.
          - 3.1.2.2.4.1 Strain Relief Grommet  
HEYCO, for above 16-3 cord in a 5/8 in. hole.
        - 3.1.2.2.5 Terminal Strip  
CINCH Barrier Terminal Block 10-140 (3/8 in. spacing).
        - 3.1.2.2.6 Delta Connector and Cable
          - 3.1.2.2.6.1 Delta Connector  
3M Scotchflex 25 pin Delta Socket No. 3483-1000.
          - 3.1.2.2.6.2 Microcomputer Connector  
3M Scotchflex 26 pin Socket, no. 3399-6026.
          - 3.1.2.2.6.3 Cable  
3M Scotchflex 26 wire flat cable, no. 3302/26, 10 inch;  
connectors on one end spread in pairs to mate with wider  
spacing needed by delta connector, conductor number 26  
removed at spread end, conductor number 1 cut 4 inches  
from spread end, separated back to one inch from spread  
end.
      - 3.1.2.3 Heat Sink Assembly
        - 3.1.2.3.1 Heat Sinks (2 each)  
INTERNATIONAL RECTIFIER Heat Exchanger No. HE50-3A2;  
drilled for TO-3 socket and tie points.
          - 3.1.2.3.1.1 Sockets (2 each)  
CINCH Power Transistor Socket 2TS-2.
          - 3.1.2.3.1.2 Terminal Strips (2 each)  
CINCH Terminal Strip No. 2003 (3 terminal).
        - 3.1.2.3.2 Heat Sink Side Plates (2 each)
      - 3.1.2.4 Large Transformer Assembly
        - 3.1.2.4.1 Separator Block
        - 3.1.2.4.2 Terminal Strip  
CINCH Barrier Terminal Block 3-140 (3/8 in. spacing).
        - 3.1.2.4.3 18V Transformers (2 each)  
TRIAD Dry Disk Rect. Transformer F-48U (17-18Vrms, 6A).
      - 3.1.2.5 Small Transformers
        - 3.1.2.5.1 6.3V  
STANCOR Filament Transformer P-6466 (6.3Vrms, 3A).
        - 3.1.2.5.2 24V C.T.  
STANCOR Filament Transformer P-8180 (25.2Vrms, CT, 1A).
      - 3.1.2.6 Capacitor Mount
      - 3.1.2.7 Circuit Card Assembly
        - 3.1.2.7.1 Heat sink angle
        - 3.1.2.7.2 Card
        - 3.1.2.7.3 Interface Connector  
3M Scotchflex 26 pin solder tail header no. 3493-2003.
        - 3.1.2.7.4 Interface Cable
          - 3.1.2.7.4.1 Connectors (3 each)

- 3M Scotchflex 26 pin Socket, no. 3399-6026.
- 3.1.7.4.2 Cable
  - 3M Scotchflex 26 wire flat cable, no. 3302/26, 18 inch;  
one end split 6 inches into 14 and 12 wire parts.
- 3.1.8 Fuse Block
  - LITTELFUSE 3AG Solder Terminal 2 Fuse Block, No. 357002.
- 3.1.9 Rectifier
  - INTERNATIONAL RECTIFIER Bridge Rectifier 100PB2P (10A).
- 3.1.10 Terminal Strips (3/8 in. barrier spacing).
  - 3.1.10.1 CINCH Barrier Terminal Block 4-141
  - 3.1.10.2 CINCH Barrier Terminal Block 5-141
  - 3.1.10.3 CINCH Barrier Terminal Block 6-141
  - 3.1.10.4 CINCH Barrier Terminal Block 7-141
  - 3.1.10.5 CINCH Barrier Terminal Block 12-141
- 3.1.11 Tie Points (3 each)
  - CINCH Terminal Strip No. 2004 (4 terminal).
- 3.1.12 Microswitch Assembly
  - 3.1.12.1 Adjusting Block
  - 3.1.12.2 Microswitch
    - MICRO SWITCH Short Roller Lever Std Switch No. BZ-2RW22.
- 3.1.13 Speaker
  - OAKTRON 2.5 in. Speaker, 1 Watt, 8 ohm, No. 25A8C.
- 3.1.14 Angle
  - 3.1.14.1 Back
  - 3.1.14.2 Front
    - 3.1.14.2.1 Ribbon Cable Clamp
- 3.1.15 Feet
  - WALDOM Recessed Screw Rubber Bumper, 3/8 in. high, 3/4 in. wide, 1/8 in. hole, 7/32 in. recess, No. B-324.
- 3.2 Print Assembly
  - 3.2.1 Paper Advance Mechanism
    - 3.2.1.1 Paper Advance Plate
    - 3.2.1.2 Motor Assembly
      - 3.2.1.2.1 Motor Mount Plate
      - 3.2.1.2.2 Angles
      - 3.2.1.2.3 Gear
        - BOSTON GEAR 1 in., 32 pitch, brass, No. Y3232.
      - 3.2.1.2.4 Motor
        - EASTERN AIR DEVICES Variable Reluctance Stepping Motor, 28V, 3 phase, 35 ounce-in. stall torque, No. LD20ACL-12.
    - 3.2.1.3 Bearing Mounts
    - 3.2.1.4 Shaft Assembly
      - 3.2.1.4.1 Sprockets
        - LAVEZZI MACHINE WORKS Aluminum Sprocket, .500 pitch, 12 tooth, No. L12F25K.
      - 3.2.1.4.2 Gear
        - BOSTON GEAR 1.25 in., 32 pitch, brass, No. Y3240.
      - 3.2.1.4.3 Washers
      - 3.2.1.4.4 Bearings
        - BOSTON GEAR Self Lubricating Bronze Bearing, .25 in. ID, .375 OD, .5 long.
      - 3.2.1.4.5 Shaft
    - 3.2.1.5 Terminal Strip
      - CINCH Barrier Terminal Block 4-140 (3/8 in. spacing).
  - 3.2.2 Motor Mount
    - 3.2.2.1 Motor Mount Plate
    - 3.2.2.2 Motor
      - SUPERIOR ELECTRIC Slo-Syn Stepping Motor, M092-FD09.
    - 3.2.2.3 Winding Drum

- 3.2.3 End Assemblies (2 each)
    - 3.2.3.1 End Plates (2 each)
    - 3.2.3.2 Pulleys (4 each)
      - 3.2.3.2.1 Bearings (4 each)  
SCHATZ MANUFACTURING Ball Bearing, 5.2 in. ID, 1 in. OD, No. BR9903; seals and grease removed, re-lubricated with light grease.
      - 3.2.3.2.2 Rims (4 each)
      - 3.2.3.2.3 Shafts (4 each)
      - 3.2.3.3 Bumpers (2 each)  
WALDOM Recessed Screw Rubber Bumper, 3/8 in. high, 3/4 in. wide, 1/8 in. hole, 7/32 in. recess, No. B-324.
  - 3.2.4 Front Bar
  - 3.2.5 Print Bar Assembly
  - 3.2.6 Shafts (2 each)  
THOMSON INDUSTRIES Solid 60 Case Shaft, 3/8 in. Dia, Tolerance Class L, 22.0 in. long.
  - 3.2.7 Carriage
    - 3.2.7.1 End Plates
      - 3.2.7.1.1 Cable Clamp Bolts
      - 3.2.7.1.2 Fine Adjustment Mechanisms
      - 3.2.7.1.3 Linear Bearing Assemblies
        - 3.2.7.1.3.1 Linear Bearings  
THOMSON INDUSTRIES Super-6 Ball Bushing.
        - 3.2.7.1.3.2 Washers
        - 3.2.7.1.3.3 External Retaining Rings  
THOMSON INDUSTRIES External Retaining Rings, Type W, No. W-375.
        - 3.2.7.1.4 Ribbon Cable Clamp
    - 3.2.7.2 Bottom Assembly
      - 3.2.7.2.1 Bottom Plate
      - 3.2.7.2.2 Terminal Strip  
KULKA single row terminal strip, 1/4 inch barrier spacing, 6 terminal, series 400 (CINCH type 171 will do in a pinch, though it is double row).
      - 3.2.7.2.3 Rubber Mat
    - 3.2.7.3 Top Assembly
      - 3.2.7.3.1 Top Plate
      - 3.2.7.3.2 Stylus Guide Bar
      - 3.2.7.3.3 Solenoids  
GUARDIAN ELECTRIC Intermittent Push Solenoid, 24VDC, 15 Ohm, 64 ounce at 1/16 inch, No. TP8 16-INT-24D.
        - 3.2.7.3.3.1 Styli  
Push Plunger removed from 3.2.7.3.3, straightened if needed, and ground to stylus point (Note: this grinding should be deferred until the print bar (3.2.5) has been completed). Groove filed 1/16" from bottom to hold spring.
        - 3.2.7.3.3.2 Springs  
Tapered springs, 1/2" long; tight fit around large end of stylus at small end; loose fit at large end.
        - 3.2.7.3.4 Alignment Pins
  - 3.2.8 Cable  
SULLIVAN PRODUCTS Pylon Brand, 7 Strand Stainless Steel, .018 in. dia. Control Line, (50 lb. test), No. 018-60.
- 3.3 Cabinet
    - 3.3.1 Front Plate
    - 3.3.2 Side Plates
  - 3.4 Lid

- 3.4.1 Computer Assembly
  - 3.4.1.1 Single Board Computer
    - CROMEMCO Single Card Computer
  - 3.4.1.2 Card Guides
    - 3.4.1.2.1 Metal Part
    - 3.4.1.2.2 Plastic Part
    - 3.4.1.2.3 Retainer
  - 3.4.1.3 Connectors
    - 3.4.1.3.1 S-100 Connector
- 3.4.2 Internal Switch Assembly
  - 3.4.2.1 Angle
  - 3.4.2.2 Switches
    - ALCOSWITCH On-off-on SPDT Miniature Switch, No. MST-105E (ALCO MTA-106E and C&K 7103 are equivalent)
- 3.4.3 External Switches
  - 3.4.3.1 Power
    - ALCO MTG-106D Snap Action SPST Canopy Switch 15A, 125VAC
  - 3.4.3.2 Print Option
    - ALCOSWITCH Miniature SPDT Toggle Switch, No. MTA-106D; this switch is small to make it easily distinguishable from the power switch (C&K 7101 is equivalent).
  - 3.4.3.3 Line Feed and Page Eject Buttons
    - GRAYHILL Push Button Switch, SPST NO, No. 4001 (GRAYHILL No. 2201, snap action, may be preferable); the important thing is that the switch button be relatively large without requiring much back panel space.
- 3.4.4 Terminal Strip
  - CINCH Lug Type Terminal Strip No. 54 (4 lug).
- 3.4.5 Wire Hold Downs
  - WALDOM Nylon Cable Clamp, 3/8 inch dia., CCN-35.
- 3.4.6 Cable to Switches
  - 3.4.6.1 Connector
    - 3M Scotchflex 26 pin Socket, no. 3399-6026.
  - 3.4.6.2 Cable
    - 3M Scotchflex 26 wire flat cable, no. 3302/26, 14 inch.
- 3.4.7 Paper hold-downs (2 each)
  - 3.4.7.1 Struts (2)
  - 3.4.7.2 Mounting Blocks (2)
  - 3.4.7.3 Ball Bearings (4)
    - 5/8" diameter, 1/4" bore, 0.2" wide
  - 3.4.7.4 Pivot Pins (2)
  - 3.4.7.5 Pivot Washers (2)
  - 3.4.7.6 Bearing Washers (8)
  - 3.4.7.7 Springs (2)
    - 1/8" dia. coil tension springs,
    - 1.3" long unextended
- 3.4.8 Back Hinges (2 each)



#### 4 Electronics

##### 4.1 Driver Circuits (11)

###### 4.1.1 Transistors (11)

RCA SK 3180 NPN Si Darlington Transistor  
 $P_T=65W$ ,  $I_c=10A$ ,  $V_{cb0}=80V$ ,  $V_{ce0}=30V$ ,  
 $V_{eb0}=5V$ ,  $h_{fe}=20K$ , Case TO-220

###### 4.1.2 Pull-up Resistors (11)

470 Ohm, 1/8 Watt.

###### 4.1.3 Diode (10)

1N4002

###### 4.1.4 TTL Buffer (2)

SN7407N hex noninverting buffer

###### 4.1.5 Power dissipation resistors (4)

5 Ohm, 5 Watt

###### 4.1.6 Resistor for speaker circuit

12 Ohm, 2 Watt

###### 4.1.7 Capacitor for speaker circuit

15 uF, 10V

##### 4.2 Current limiter circuit (2)

###### 4.2.1 Transistor (2)

RCA SK3173 PNP Si Bipolar Transistor  
 $P_T=125W$ ,  $I_c=-15A$ ,  $V_{cb0}=-90V$ ,  $V_{ce0}=-80V$ ,  
 $V_{eb0}=-5V$ ,  $h_{fe}=70$ , Case TO-3

###### 4.2.2 Diode (2)

1N4002

###### 4.2.3 Zener Diode (2)

3.3V, 1W

###### 4.2.4 Resistor (2)

280 Ohm, 2 Watt

###### 4.2.5 Resistor (2)

###### 4.2.6 Resistor (2)

0.5 Ohm, 12 Watt

###### 4.2.7 Fuse (2)

1.6 Amp (?)

##### 4.3 Switch Circuits

###### 4.3.1 Capacitors (3)

0.1 uF disk capacitor

###### 4.3.2 Pull-up Resistors (2)

1000 Ohm, 1/8 Watt

##### 4.4 Terminal Strips

Strip	#terminals	Location
A	10	Rear Panel
B	2	Transformer Mount
C	7	Base Plate
D	12	" "
E	4	" "
F	4	" "
G	6	" "
H	5	" "
I	4	" "
J	4	Paper Advance Plate
K	4	Base Plate
L	6	Carriage
M	4	Computer Mounting Plate

## 5 Embedded Computer Programming

### 5.1 Computer Hardware

#### 5.1.1 Input/Output

##### 5.1.1.1 Serial Port

A UART chip is present on the computer card. This chip, with its support circuitry, drives an RS-232 port, which is the printer's means of connection to the host computer. Although both input and output are available, only input is used, as no data is sent to the host computer.

##### 5.1.1.2 Parallel Ports

24 bits of parallel input and output are available. These are used to drive the electromechanical parts, and to read the switches on the printer.

#### 5.1.2 Timers

Four programmable timer interrupts are available on the computer card. These are used whenever timing is needed.

#### 5.1.3 Interrupts

Serial I/O and the timers cause interrupts of the processor.

#### 5.1.4 Processor

Z-80A

#### 5.1.5 Memory

1024 bytes of RAM

8192 bytes of ROM. The ROM chip is Erasable, programmable; 4 are required (2716 chips).

## 5.2 Software

The program burned into the read-only memory of the computer is responsible for all operation of the printer; there is no function not mediated by the computer. The software can conveniently be divided into two parts: "foreground" and "background."

The foreground subroutines are those which are driven by interrupts: they run independently of other processes, and tend to be those which demand precise timing. For example the programs which drive the solenoids or the speaker are driven by the timer interrupt.

The background subroutines have a lower priority, running whenever all foreground routines have (for the time being) given up their claims to execution. The background process is responsible for the translation of ascii to Braille. It sends its output -- consisting of 40-cell buffers, each representing exactly one line to be printed -- to the foreground routine to be punched into the paper.

### 5.2.1 Background Process

Subroutine	Function
transl	read a character from the input queue, then call the appropriate translation subroutine to process it (transp, compnot, or gradel)
transp	if char is control char, call control, else call pchar with low-order 6 bits
compnot	if char is control, then call "control", else if char is space, add 1 to space count else print out the space buffer with either blanks or countable spaces, depending on how many there are. Then look up the char in cntbl, and call pcharx with the resulting cell(s).
pcharx	if at end of line, go to beginning of next line and print the overrun character. Then print the char passed to pcharx.
levell	Store char in glc, then decide which kind of char it is: A-Z: b $\leq$ 0; a-z: b $\leq$ 1; 0-9: b $\leq$ 1; punct: b $\leq$ 3 space or control char: b $\leq$ 4. Then call statem with b and the char.
statem	This is a finite state machine. Current state (0-5) is given by gls; for each state there are five possible action routines index from register b. These are labelled z1 through z18. These do such things as changing state, setting variable gll, and calling the subroutine "output"
output	Looks up the character passed in outtbl or ltable, and sends the resulting cell(s) to pchar.
control	call a subroutine depending on the value of the control character passed. Typical subroutines: plf for linefeed, pvt for vertical tab, pcr for carriage return, pbel for bel, pnul does nothing.

plf pass the address of the linefeed routine to swbuf

pcr set column to -1 (which is the left margin)

pesc read a char from the input queue. depending on its value, reset the variable which points to the current translation routine to either compnot, transp, or gradel.

pchar increment column. If this makes it equal to the position of the right margin, call pcr and plf. Then pass the char to print (which was the parameter) to "write".

swbuf mark the buffer just completed as "ready to print." then wait for the other buffer to become available, and set it as the one to write to. Then initialize the new write buffer.

write If the current print position in the buffer marked for writing is empty, write the character there, and return. Else, if the corresponding print position (given in both cases by -column-) in the underscore line is empty, write it there. Else do nothing.

## 5.2.2 Foreground Processes

### 5.2.2.1 Reading from Serial Port

`indata` called by serial port interrupt; reads char from port, masks out the parity bit, and calls `putql`

`putql` puts character into the input queue

### 5.2.2.2 Polling the switches

`intlize` initializes state variables for switch polling and paper advance mechanism; starts up the interrupt to call `readsw` every 250 ticks (every 16 msec)

`readsw` debounces the switches by waiting 16 msec for the to settle. When a transition is detected and debounced, calls `actnow`

`actnow` checks linefeed button, formfeed button, mode switch. Calls `makelf` or `makeff` for linefeed or formfeed only if carriage is not in motion. If mode switch is switched, puts appropriate escape sequence into the input queue (ESC 5 or ESC 6)

### 5.2.2.3 Carriage and solenoid motion

`fore` Waits for buffer to be marked for punching. If first line is nonzero, calls `punline` to punch it. Then if underscore line is nonzero, generates a half line feed, and calls `punline` on the underscore line. Then calls whichever paper advance routine was specified in the buffer, and marks the buffer as ready to write to. Then waits for paper advance to finish, and starts over again.

`punline` if carriage is at right, calls "`punl`" to punch while going leftwards; if carriage is at left, calls "`punr`" to go rightwards.

`punr` initializes `carcol` to -1 (just before leftmost cell). Then call `nextr` to determine both the next 3-dot punch to make (one dot from cell N, one from cell N+5, and one from cell N+10), and the number of carriage steps needed to get to the right place to make it.  
Then:  
REPEAT call `movpun` to move and punch; call `nextr`  
UNTIL `nextr` says there is nothing more to punch  
Then if `paper=narrow`, call `carrmar` to move to right margin; else (`paper=wide`) call `carlmar` to move to left margin.

`punl` similar to `punr` (calls `nextl` and `movepun`).

`nextr` Keep incrementing `carcol` and calling "`read`" until something is found; if nothing is found return a 0, else calculate number of steps to get there, and return both the bits to punch and the number of steps.

nextl similar to nextr

movpun call nsteps to move the distance passed as parameter; wait a short time; call pun to punch the solenoids with the appropriate values; wait some more.

nsteps calculate destination, and store it for purposes of being able to recover if something misses. Then accelerate using the 100-step acceleration sequence (or as much as is needed of it), coast (if more than 200 steps total), and then reverse the acceleration sequence to decelerate.

pun output the bits to the solenoids; wait a while; turn off the solenoids so they can retract.

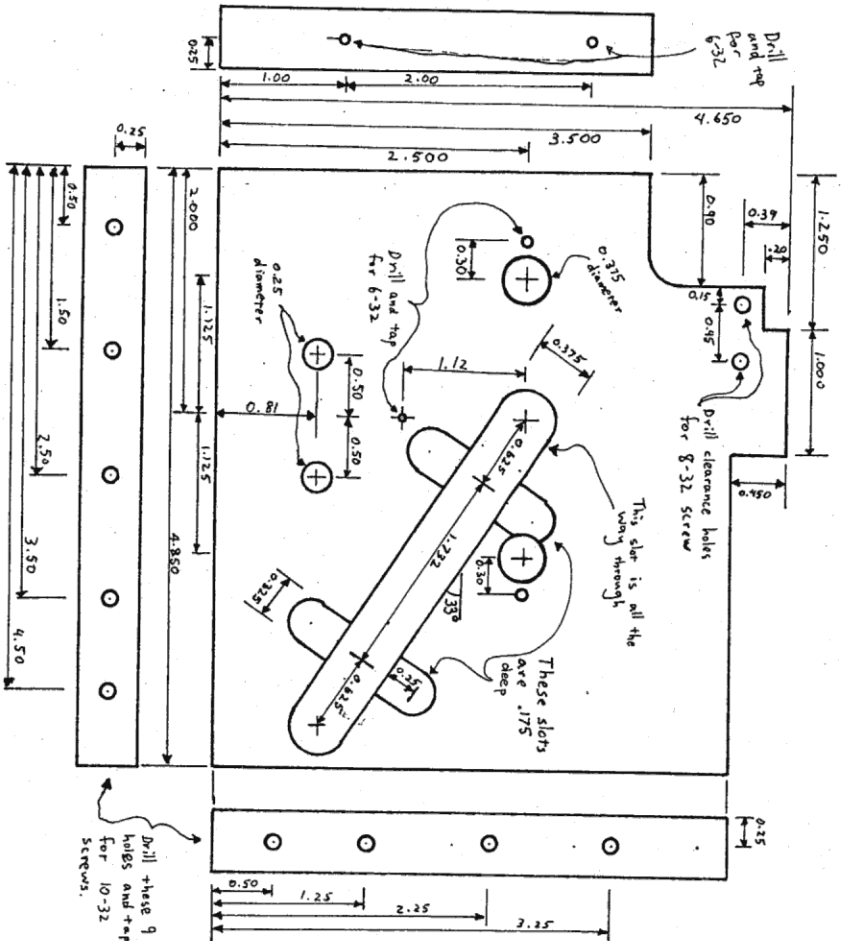
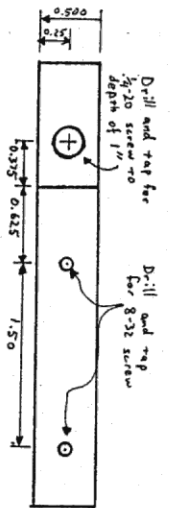

**RIGHT PULLEY MOUNTING PLATE**  
 Note: The Left Pulley Mounting Plate is the same except that the .0175 deep slots are on the other side.

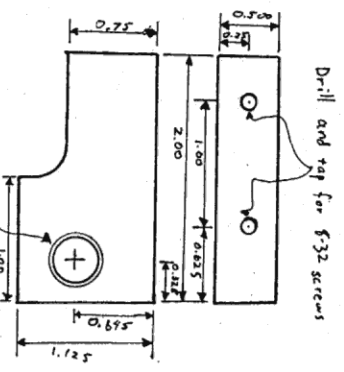

Drill 0.375 through, then drill .397 dia. to depth of 0.15 from each end.

**PAPER ADVANCE SHAFT SUPPORT**  
 (2 REQUIRED)

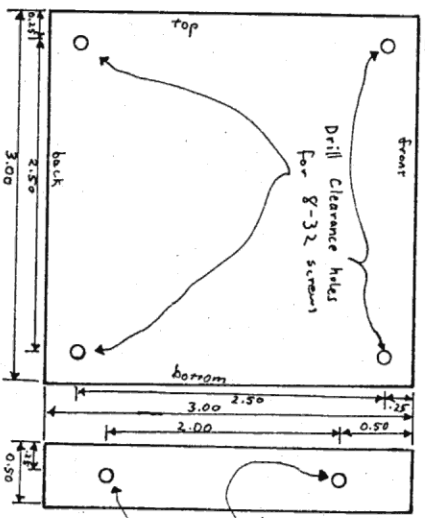
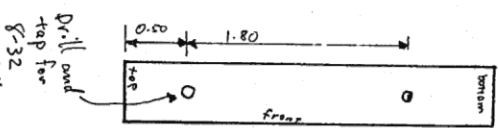

**TRANSFORMER MOUNT**

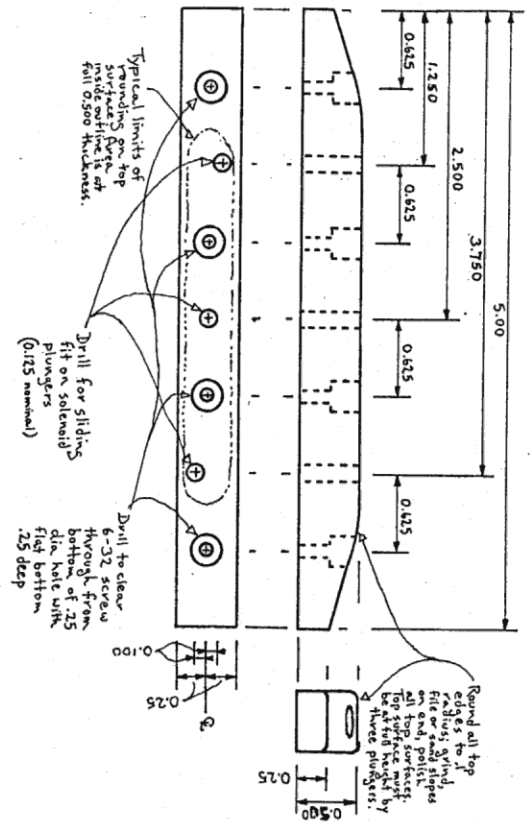

### CARRIAGE - DIE GUIDE

Material:  $\frac{1}{2}$  inch sq. brass bar.

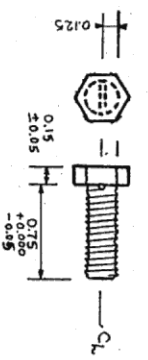

Made from a  $\frac{1}{4}$  -20 x  $\frac{3}{4}$  brass bolt  
 Drill through bolt to die, just under head.  
 If the resulting hole is not flush to the plane of the underside of the head, use washers to get this effect.  
 Make 2

### CARRIAGE - CLAMP BOLTS

Make 4. 0.50 x 0.25 dia. pins to fit in slots in Carriage End Plates  
 The upper pin in each end plate is fixed by 2 6-32 x  $\frac{3}{8}$  round head screws  
 The lower pin in each end plate is adjusted by a 10-32 x  $\frac{7}{16}$  allen head set screw  
 Make 2. 1.00 x 0.150 dia. pins (dia. to .0005 - .0001) to hold carriage top plate to end plates  
 Fix top plate to end plate with 4 8-32 x  $\frac{3}{4}$  cap screws, slots with pins in and plates face each other  
 Loosely mount Clamp Bolts in 4 in dia. holes in end plates, bolt head inside, nut outside  
 Mount solenoids loosely in holes in top plate from inside with nuts in wells on outside  
 Mount die guide on top plate with 4 6-32 x  $\frac{3}{4}$  cap screws, check for free sliding of solenoid plungers  
 Mount bottom plate between ends of end plates, well facing up, 2 mounting holes in side facing opposite the ramps on the end plates, with 4 8-32 x  $\frac{3}{4}$  screws.  
 Tighten all butt clamp bolts, insert ball bushings in large holes in end plates, attach terminal strip to side of bottom plate with 2 4-40 x  $\frac{3}{8}$  screws.

### CARRIAGE - ASSEMBLY

Dimensions are in inches, expressed as:  
 0.00 are  $\pm 0.005$   
 0.00 are  $\pm 0.0005$   
 0.000 are  $\pm 0.0005$   
 Unless otherwise specified.

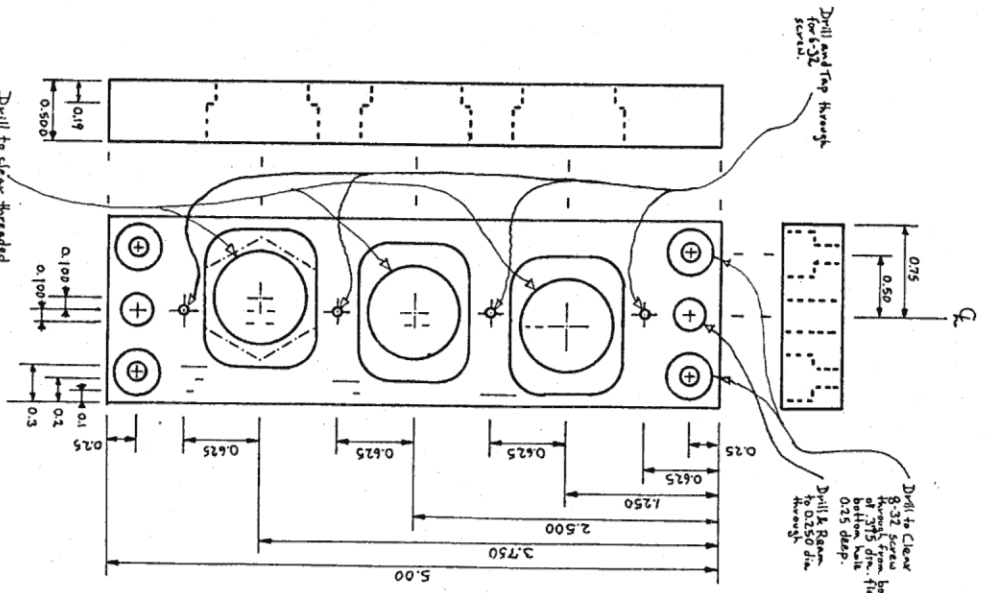

### CARRIAGE - TOP PLATE

Dimensions are expressed as:  
 0.00 are  $\pm 0.005$   
 0.00 are  $\pm 0.0005$   
 0.000 are  $\pm 0.00005$   
 All dimensions are in inches  
 Material:  $\frac{1}{2}$  inch aluminum plate  
 Drill to clear threaded (dia. to .0005 nominal) through from bottom of reamed hole with 0.01 deep with a drill and supplied with steel nut and a (nominal) 0.01 wide, 0.90 (leg), corner 0.5 dia.)







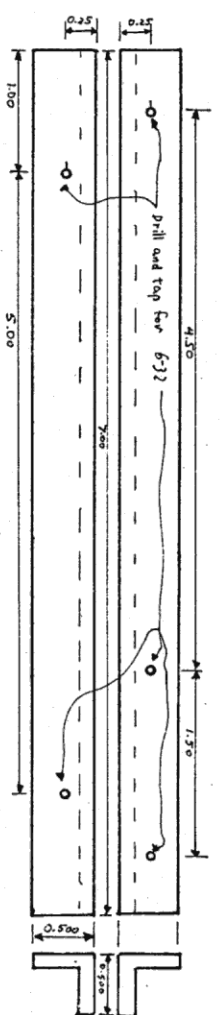
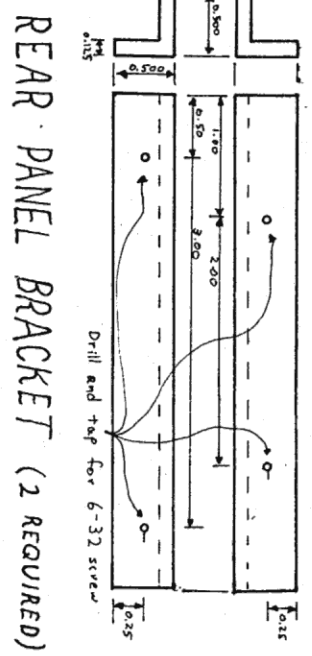
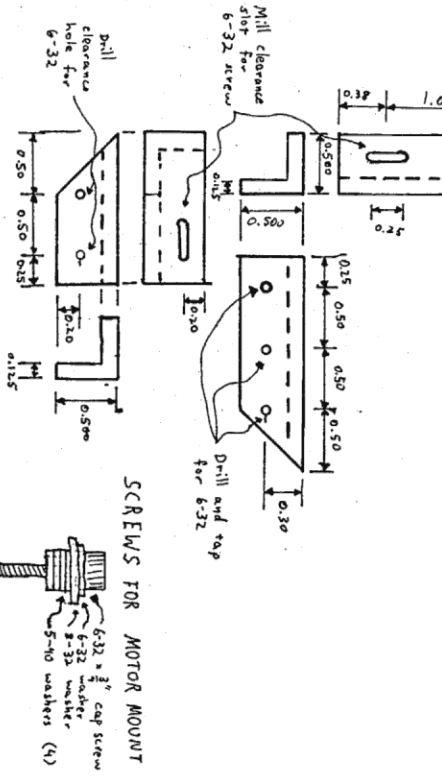
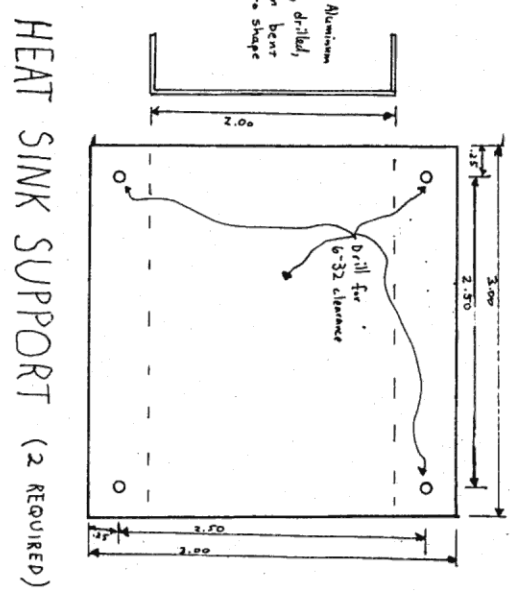
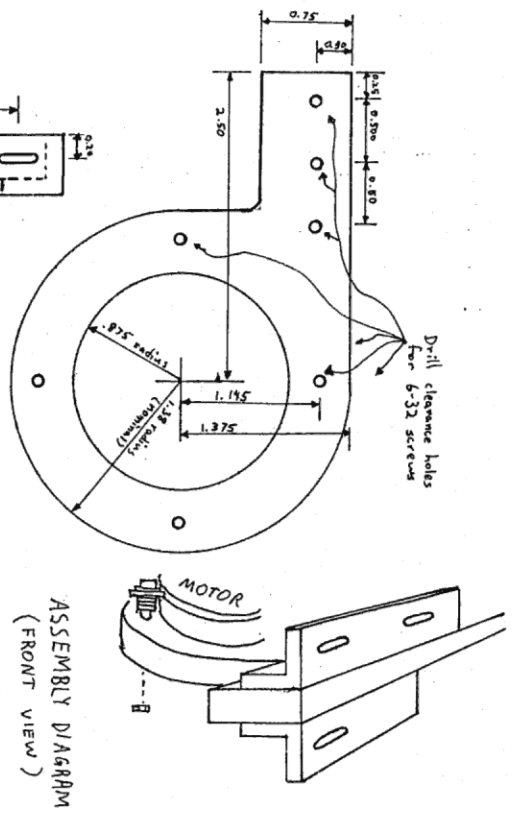

PAPER ADVANCE MOTOR MOUNT





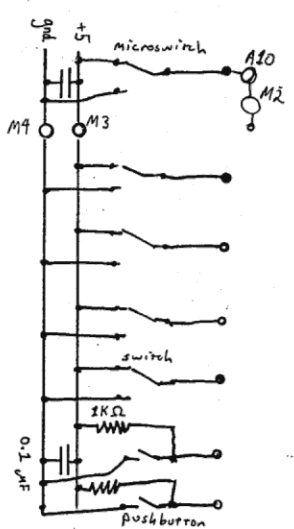
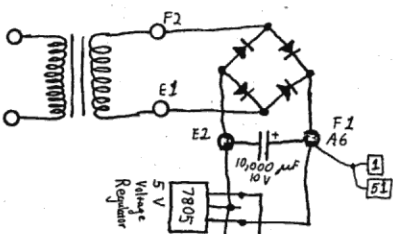
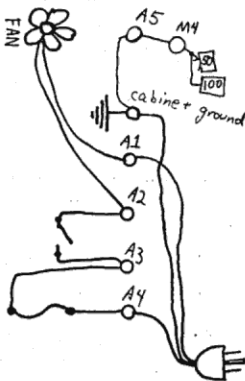
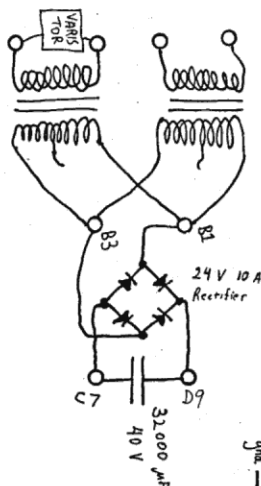
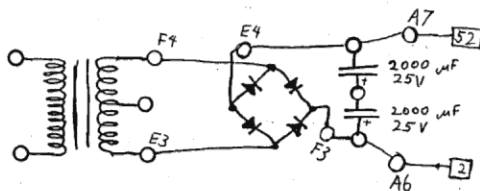

These circles O and accompanying letter-number pairs refer to terminal strips, the letter indicating which strip and the number referring to which terminal on the strip numbering from back, left, or bottom.

These circles O are terminals on a parallel port connector on the computer card. The first digit indicates which plug (from left when looking down at the connector)

and the second number indicates position on that plug. (See Diagram Labelled "Cromenco SCC connector layout")

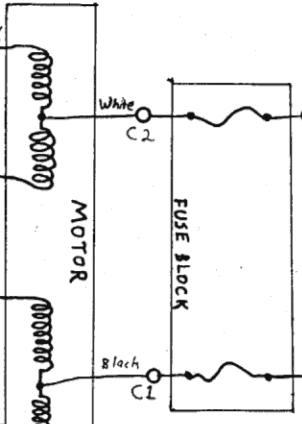
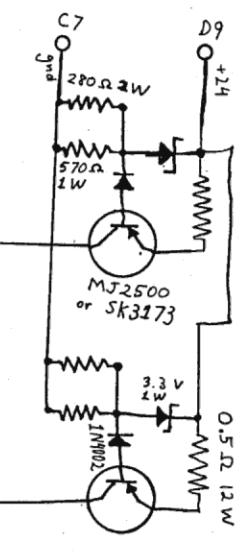
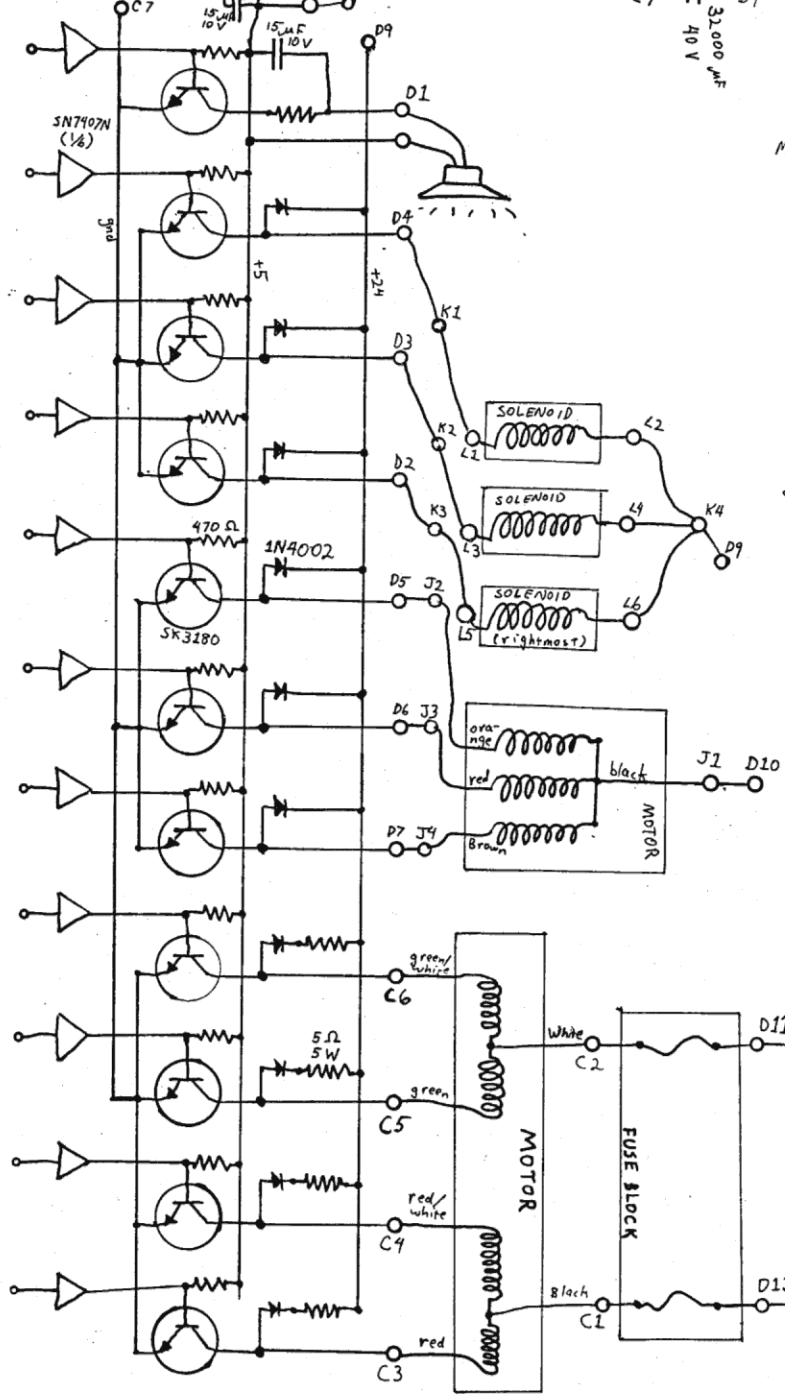



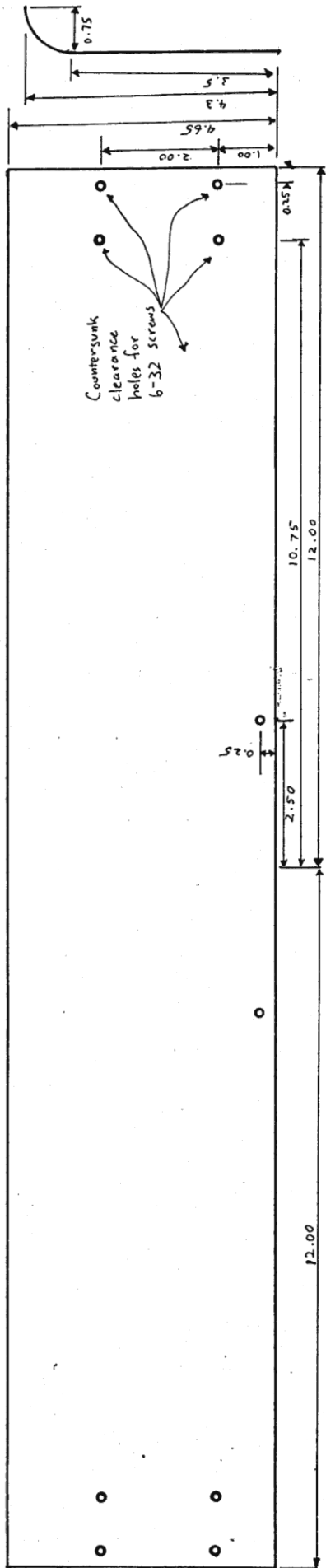

FRONT PANEL (Thickness:  $\frac{1}{16}$ )

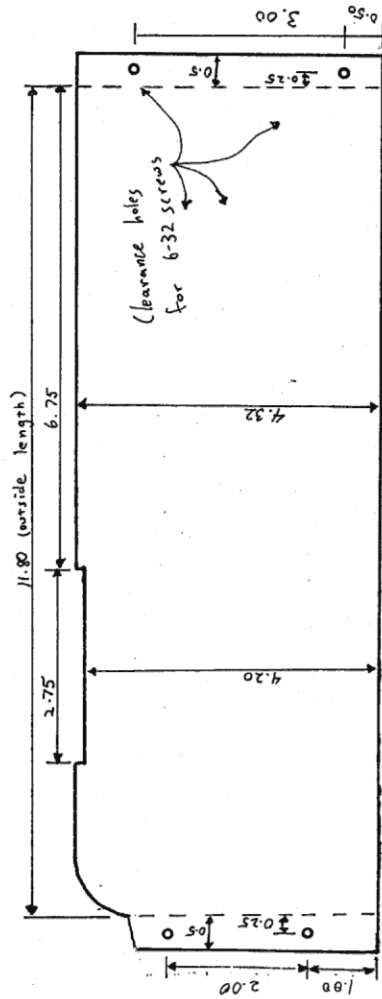

Make 2 of these, one bent in each direction

SIDE PANEL (Thickness:  $\frac{1}{16}$ )

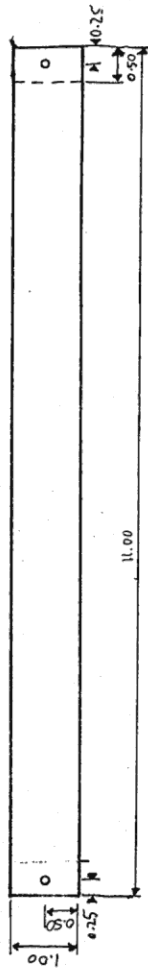

CAPACITOR CLAMP

(Thickness:  $\frac{1}{16}$ )

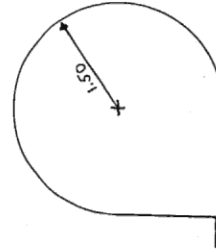



# BASE PLATE LAYOUT

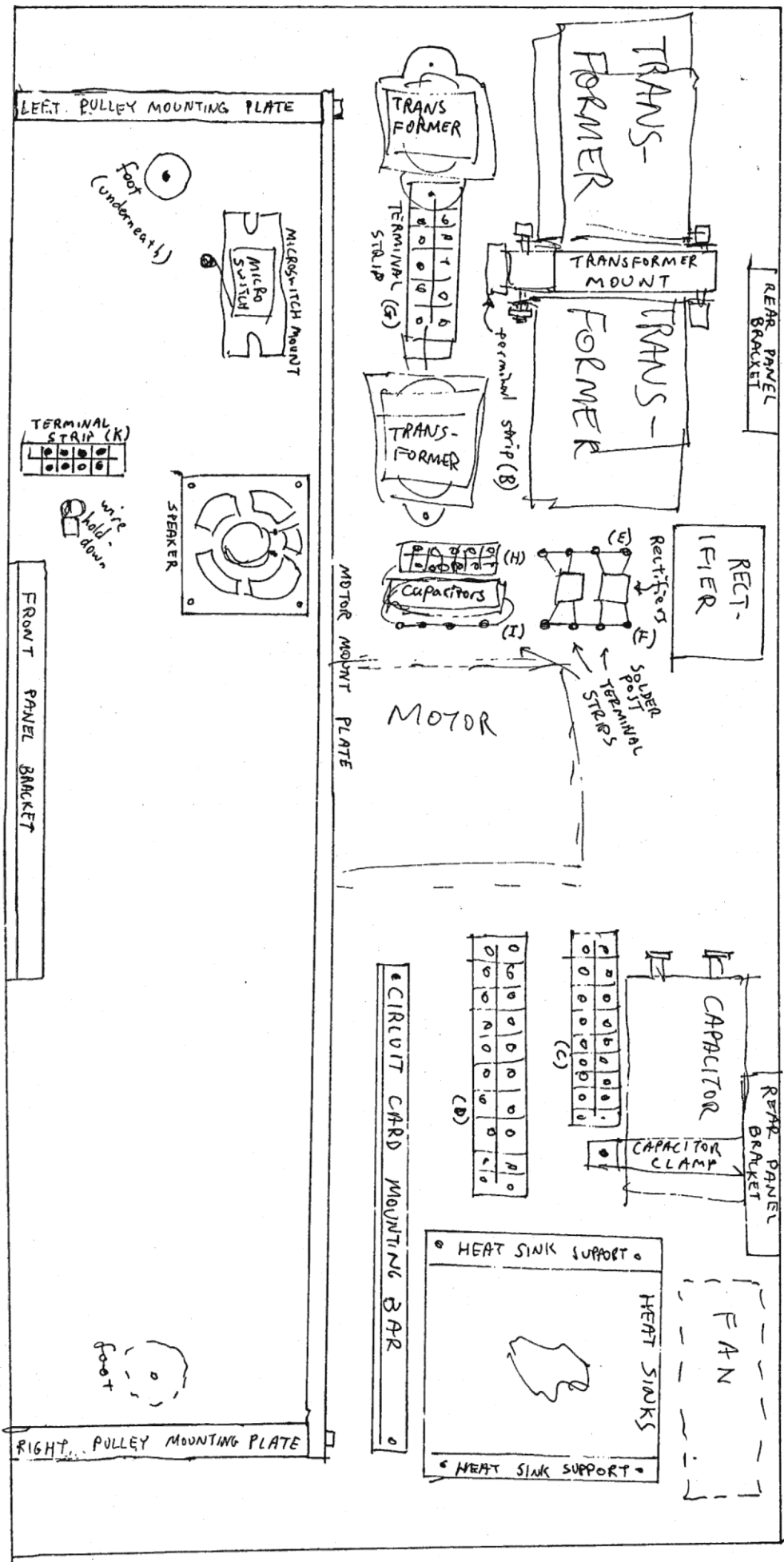

BACK VIEW OF PAPER ADVANCE PLATE

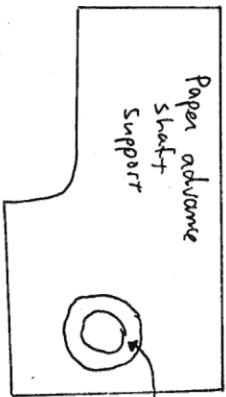
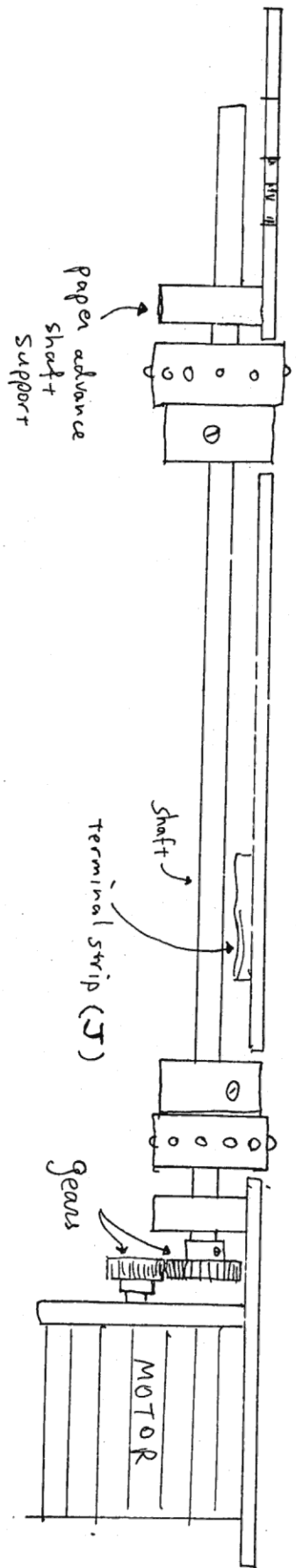

Paper advance shaft support

Glass Bronze bearing, .375 O.D., removed to dia. of shaft ( $\frac{1}{4}$ " )

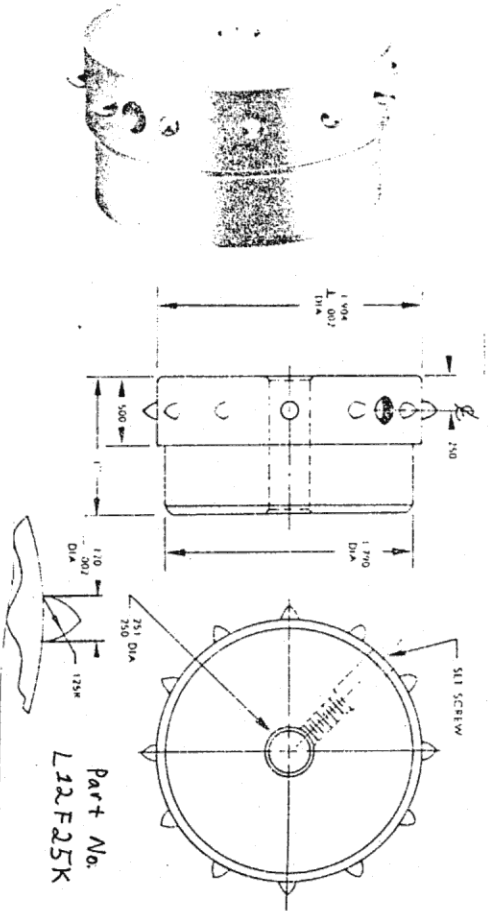

Part No. L12F25K

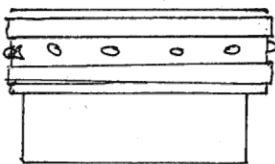

put two rubber tires on the wheel ( $\frac{1}{8}$ " rubber bands work well)

PAPER ADVANCE ASSEMBLY

Salvaggi machine works, inc.

PAPER ADVANCE ASSEMBLY

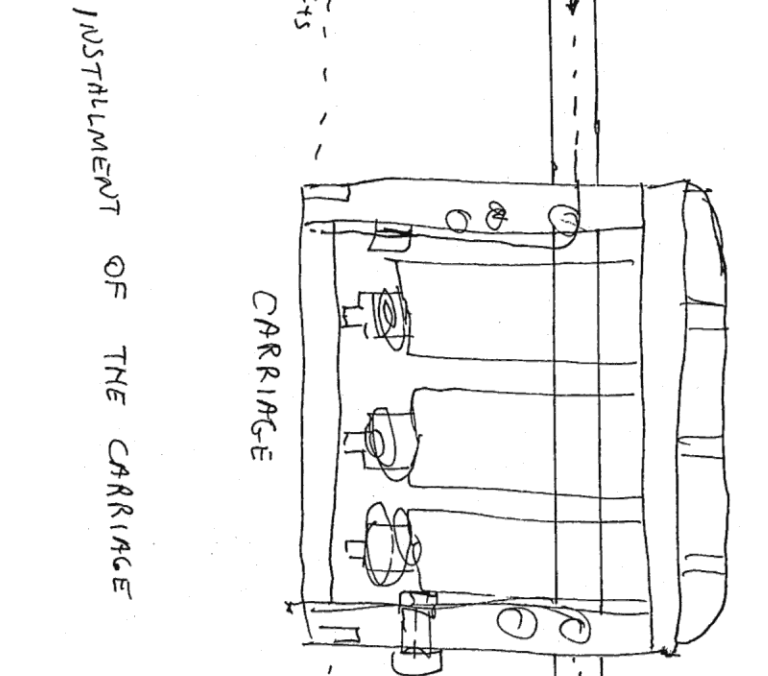
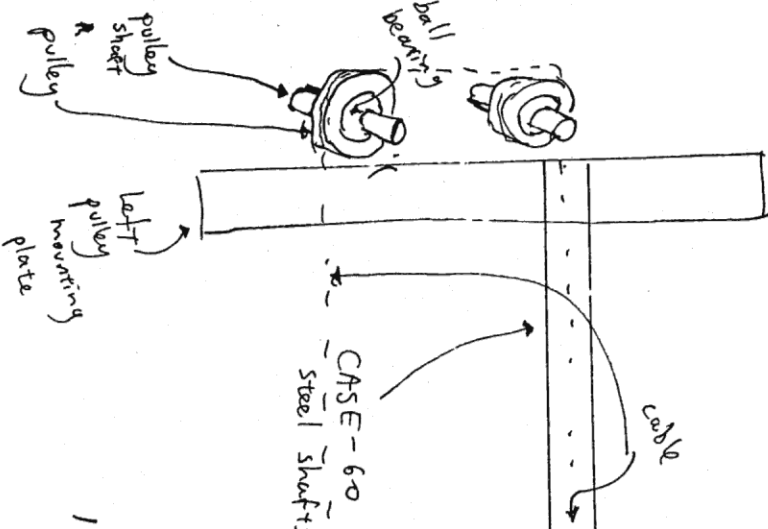

INSTALLMENT OF THE CARRIAGE

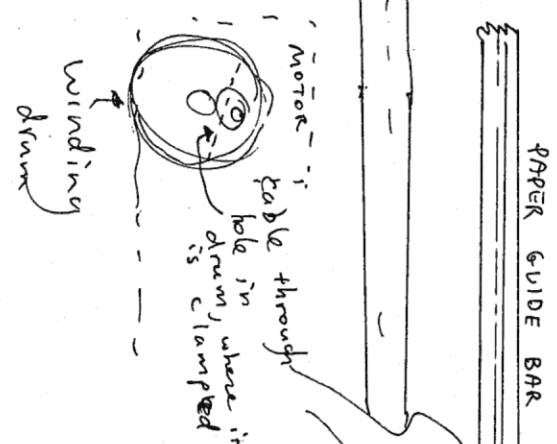

PAPER GUIDE BAR

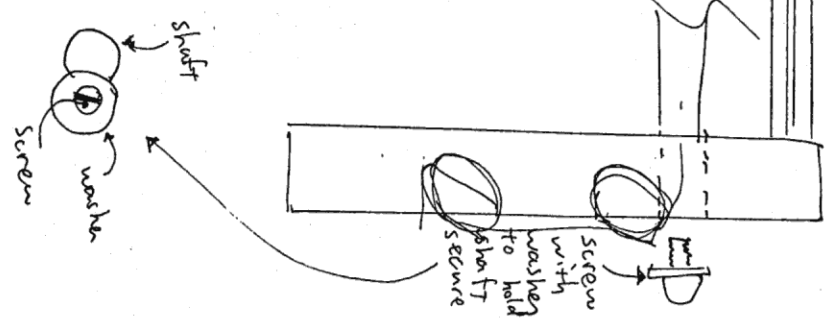

# ASSEMBLY AND OPERATION OF PAPER HOLD-DOWNS

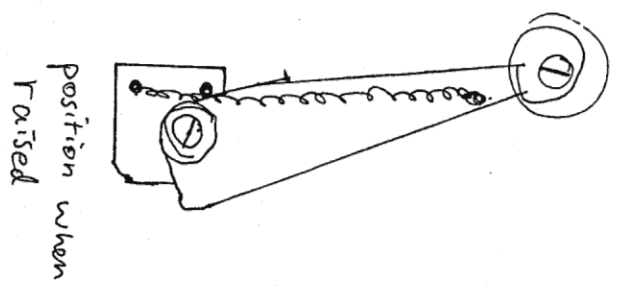
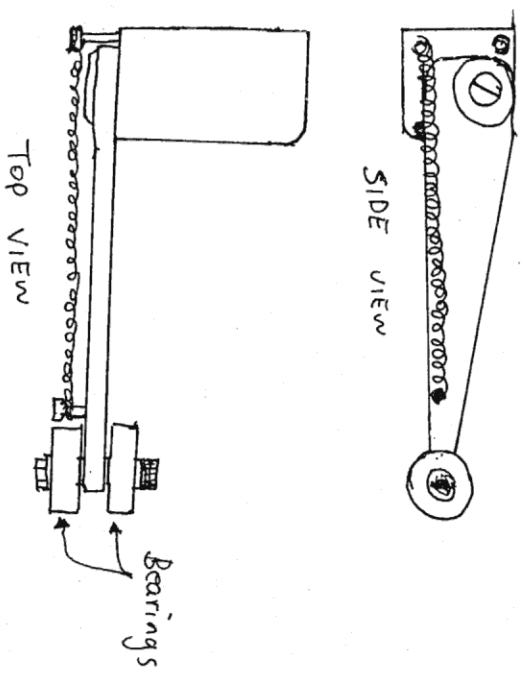

## PLATEN MOUNT BAR

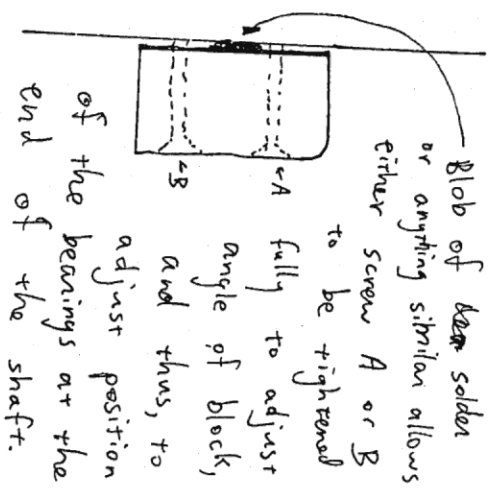

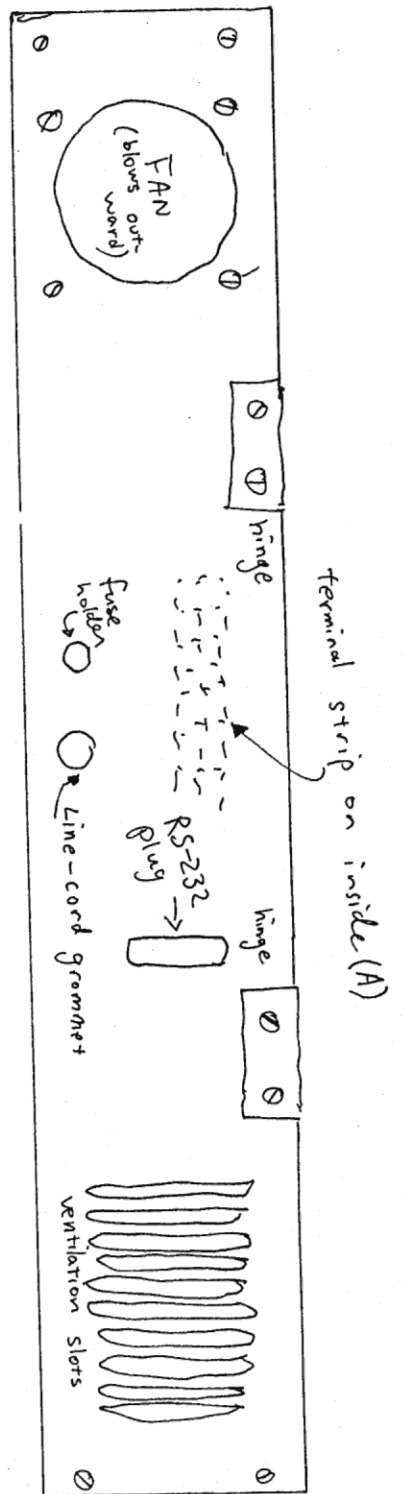

LAYOUT OF REAR CABINET PANEL

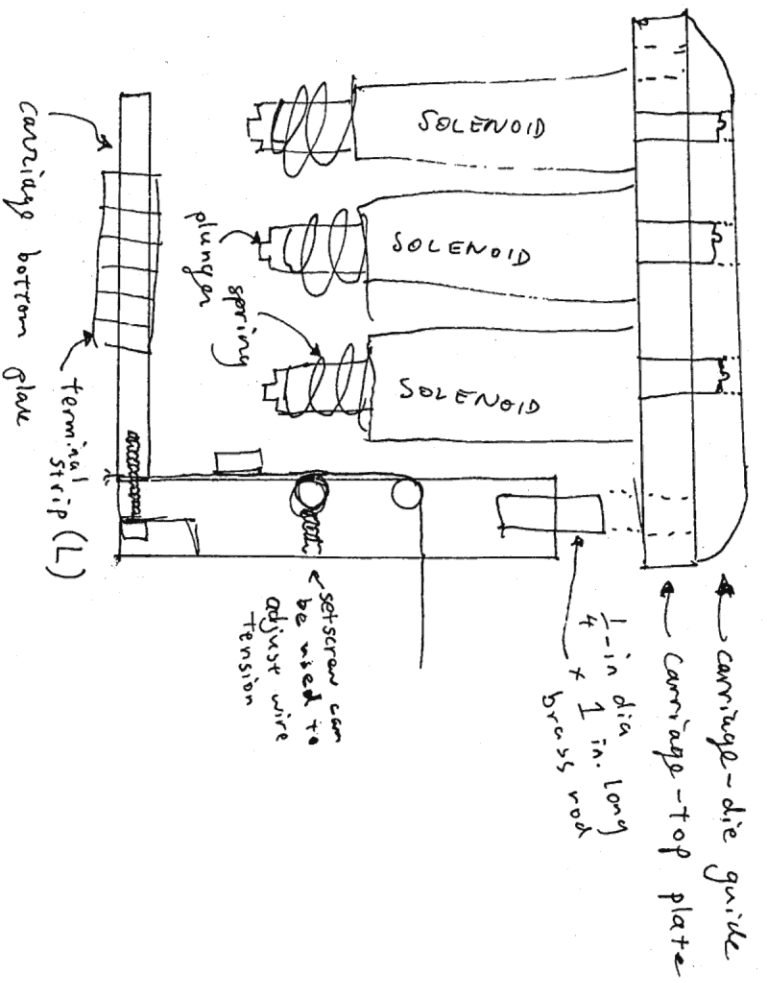
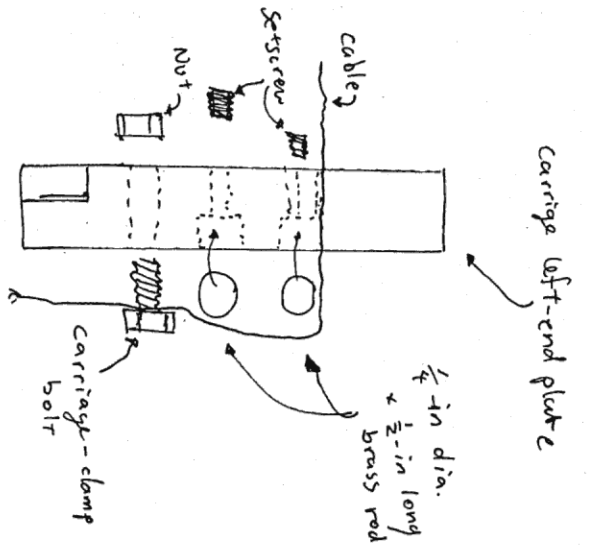

Put rubber into trough in carriage bottom plate to support solenoid plungers when at bottom of travel.

### CARRIAGE ASSEMBLY

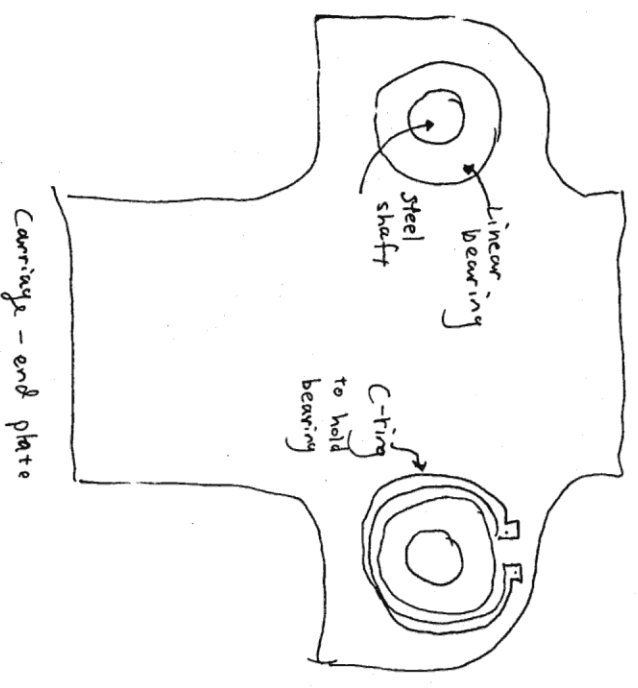

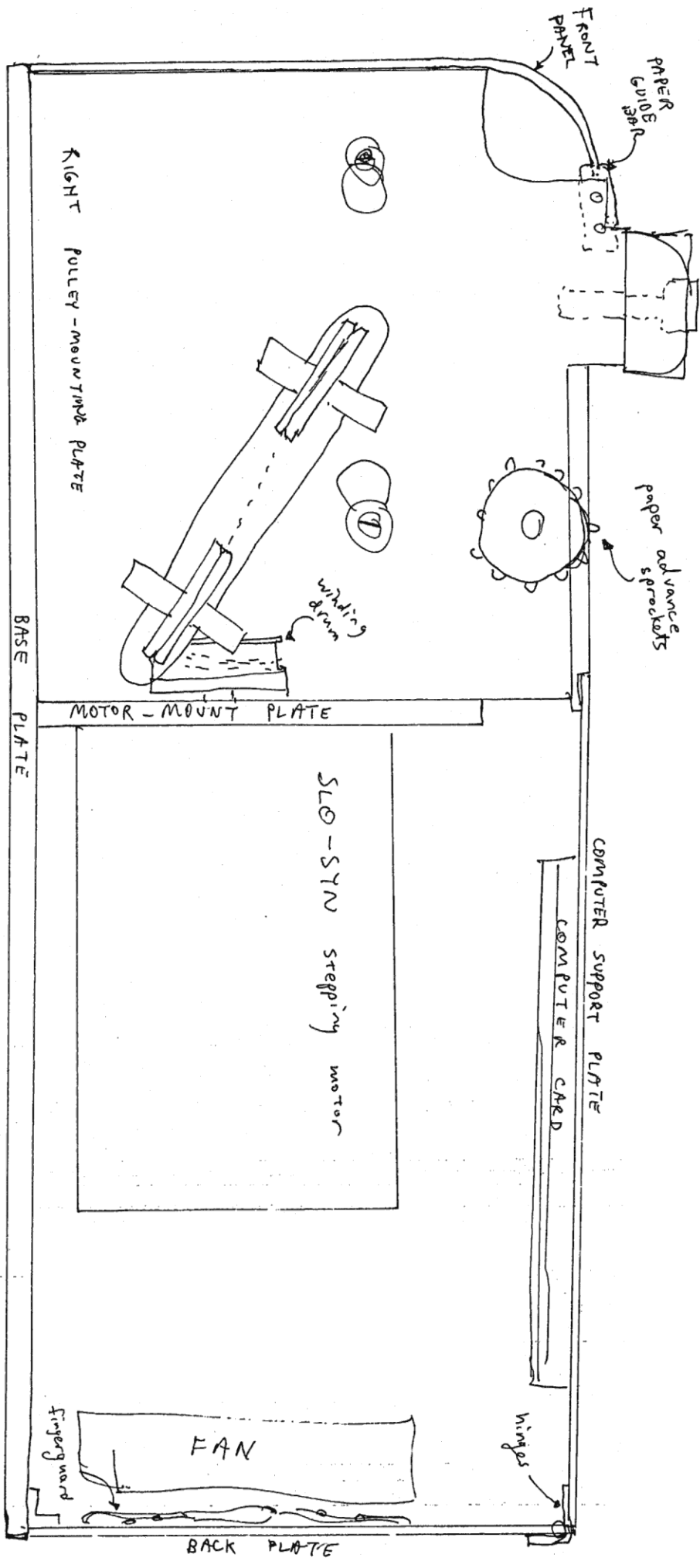

RIGHT SIDE VIEW

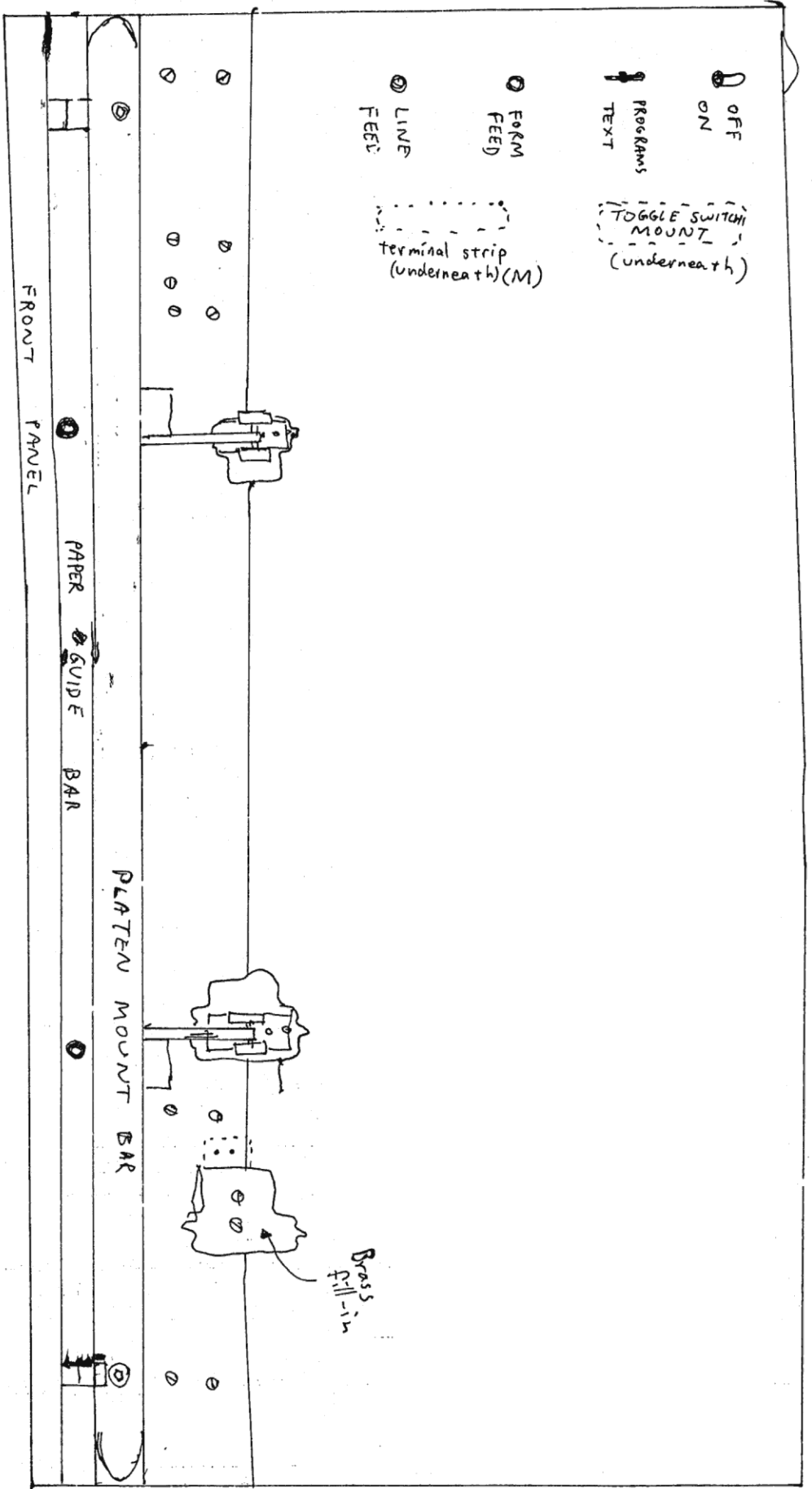

TOP VIEW OF PRINTER



## Installing the carriage cable:

Use a six-foot length of cable. Feed it through the hole in the winding drum, and tighten the clamp screw in the winding drum, with an approximately equal length of wire on either side. Then wind around the drum 3 times on each side of the ~~wire~~ clamped wire.

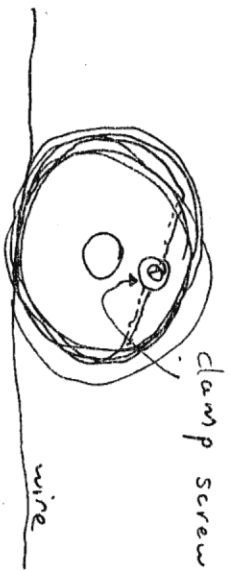

Then feed the wire around the pulleys on each end plate, and through the small hole in each carriage end-plate, down around the short ~~brass~~ brass rod, down through the carriage clamp bolt, through the holes in the ends of the carriage bottom plate, and down through the large holes in the base plate. ~~At~~ Clamp one clamp bolt, then attach a twenty-pound weight to the other end of the wire. Then clamp the clamp bolt above the weights. Cut off the wire even with the bottom of the carriage.